

MICRO-LUBRICATION LUBETOOLS

The micro-lubrication systems are designed for use primarily in the varied metal cutting and forming processes to enable the replacement of flood and water-soluble coolants. Due to the way the systems deliver a precise minimal quantity of heavier than air lubricating oil droplets to the cutting edge via individually adjustable pneumatic pumps there is no misting effect in the atmosphere. No generation of friction / heat between the work surface and the tool cutting edge, and the lubricating oil is consumed in the machining process. Just a small quantity of oil does the job and he is naturally consumed in the cutting process, so there is no harmful misting or hazardous waste disposal to worry about and that can mean higher productivity, since you do not spend time cleaning parts or disposing of used coolants. They prevent heat build-up and control heat distortion, so you get a truer cut and cleaner machine operation. Since tools and parts stay at room temperature during cutting operation, tool life is dramatically increased and maintenance and replacement costs are reduced. Reduced handling and storage of hazardous materials means a safer, cleaner working environment. And clean-up is easy, using just soap and hot water (160°F /70°C).

ADVANTAGES

- less machine down time
- increased tool life
- no coolant handling or disposal problems

THE UNIQUE ADVANTAGES OF LUBETOOL

- Lube tools regulate the lubricant supplied in exact quantities adjustable from 0 mm³ to 39 mm³ – no guesswork.
- 100% pneumatically controlled positive displacement pumps.
- Lubricant is carried by air, with pinpoint accuracy. Hazardous atomizing and “mist” are eliminated.
- All pumps and nozzle operate independently for lubricant.
- Additional pumps can be added in the field. Just order a complete pump assembly.
- Minimal or no equipment modification is required for system installation.
- A pneumatic timing device (frequency generator) with a control range
- Easy lubricant and air flow adjustment.
- Durable reservoir. Standard hose length is 5 m. Additional hose length available upon request.
- Multiple nozzle types available.

Modification of indicated specifications and design reserved

APPLICATIONS



BAND SAWING



CIRCULAR SAWING



MILLING



ENGRAVING



TAPPING



BORING



DRILLING



BROACHING



TOOL AND CUTTER GRINDING



ROLLING



GEAR CUTTING



BENDING



PUNCHING



ROLLFORMING

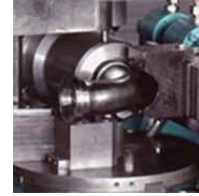

PIPES BENDING



STAMPING



TURNING



PROTECTING COATING SPRAY



MONO AND BE RAILS CONVEYERS



CHAINS



FOOD INDUSTRY

Modification of indicated specifications and design reserved

WORKING PRINCIPLE LUBETOOLS

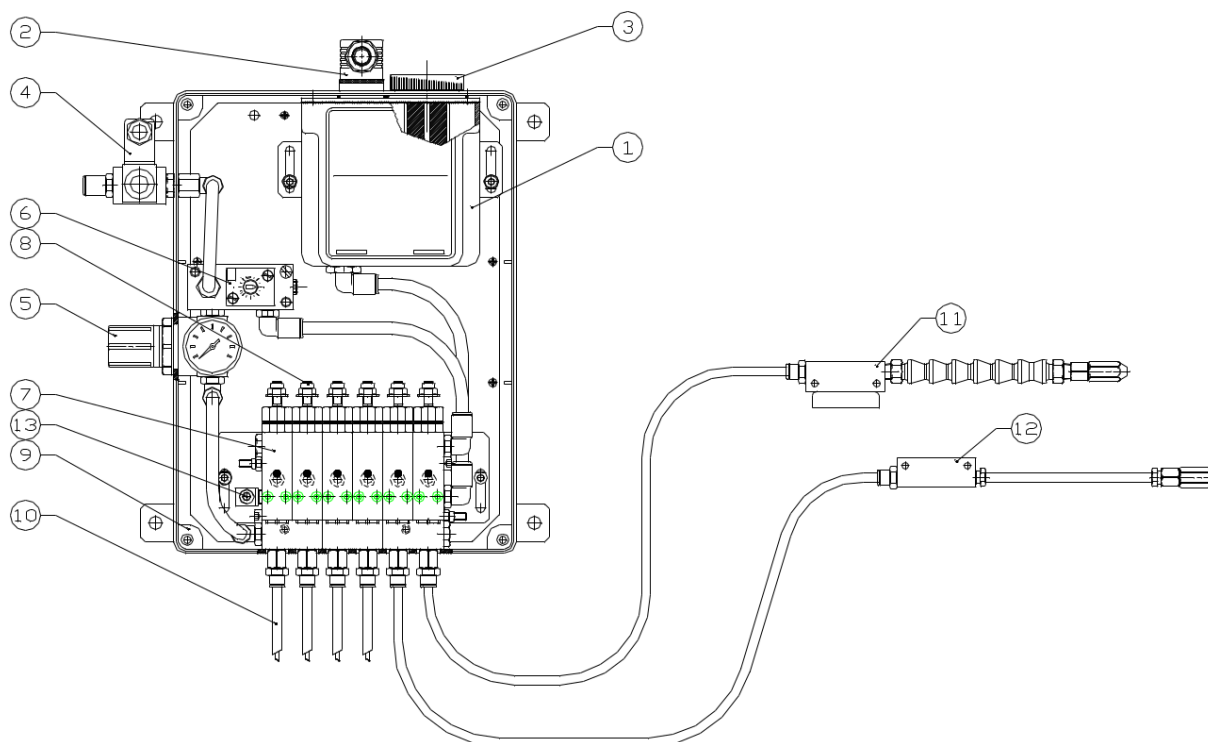

- 1. Liquid reservoir:** semi-transparent, nylon impact resistant has a capacity of 1.2 L, 2.2 L or 3.6 L.
- 2. Low level switch:** the contact close when the reservoir is empty.
- 3. Filler cup:** to re-fill oil in the reservoir.
- 4. Air supply:** a solenoid valve with a coil 24 V DC, 24 V AC, 115 V AC or 230 V AC supply the air in the system. Air pressure should be min 5 bar (75 psi) max. 8 bar (120 psi). Very important is to install a standard particle filter (5 microns) to eliminate particles and water from entering the system. If there is problem with oil in the air system, we suggest running a coalescing filter in tandem with the particle air filter.
- 5. Air regulator with gauge:** This switch allows the flow of air to go in the nozzles. Turn switch clockwise to turn air on, and counter-clockwise to turn air off. The air pressure has to be from 0.5 bar (8 psi) to 3 bar (45 psi). We suggest 1.5 bar (22 psi).
- 6. Frequency generator:** This valve controls the frequency of the pump cycles. To increase the speed of the pumps, turn screwdriver adjustment counter-clockwise.
- 7. Pneumatic pump:** Each stroke gives an exact amount of oil to the outlet.
- 8. Oil flow adjustment:** The manual ratchets regulate the amount of lubricant that is supplied with. Each stroke of the pump (adjustable from 0 mm³ to 39 mm³ /stroke).
- 9. Box:** Durable impact-resistant locking plastic box.
- 10. Coaxial feeding line:** To supply oil separate from air to the nozzle.
- 11. Loc-line magnetic base nozzle:** Adjustable magnetic attachment to the machine.
- 12. Steel fixed base nozzle:** Fixed position with a fixed attachment to the machine.
- 13. Air drain:** To drain air from the oil system.

Modification of indicated specifications and design reserved

WORKING PRINCIPLE - DROPS INSTEAD OF LITERS

An adjustable positive displacement metering pneumatic pump delivers a minimal quantity of lubricant along a capillary tube fitted inside length of the air line to the nozzle head. At this point the lubricant droplet is introduced into the air stream and transported to the cutting edge. The lubricant forms a thin even coat on the cutting edge greatly reducing the frictional heat.

The air pressure supplied to the nozzles is adjustable via the air regulator with gauge in the range from 0.5 bar (8 psi) to 3 bar (45 psi). For most applications a setting of 1.5 bar (22 psi) is sufficient. The minimum value of air pressure required for pneumatic pump with solenoid valve and the frequency generator operation is 5 bar (75 psi), maximum working pressure is 10 bar (150 psi).

METERING PNEUMATIC PUMP

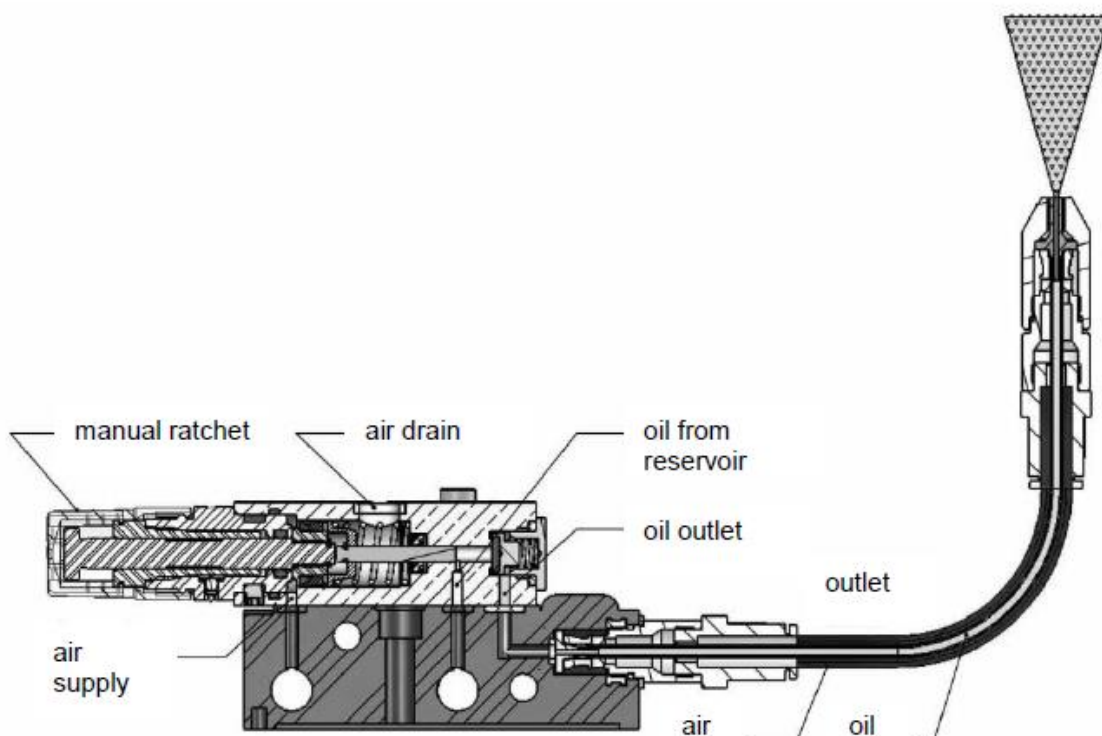

OPERATION

When the compressed air at a pressure of between 5 (75 psi) and 10 (150 psi) bar is passed to the pump it acts on the top face of the piston. The piston then operates and a precise set amount of lubricant is delivered through the outlet to the delivery port and along the capillary tube. The air is then exhausted the piston re-seats under spring pressure and the metering chamber refills with lubricant. The pump is now reset for another delivery cycle. The strokes per minute can be adjusted between 1 to 66 per minute via the frequency generator but these can vary slightly due to the lubricant used and the air pressure.

HOW TO ADJUST THE DISCHARGE PER STROKE

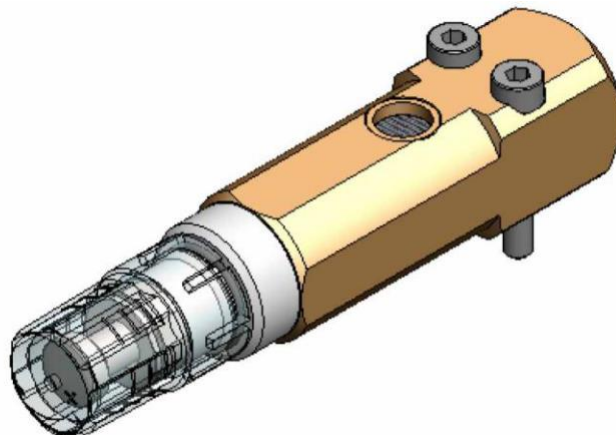

Lube tools regulate the lubricant supplied in exact quantities adjustable from 0 mm³ to 39 mm³. Stroke volume is divided into 27 basic positions (clicks), setting is carried out using the adjusting nut. Turning the adjuster clockwise will decrease the pump discharge and turning the adjuster anti-clockwise will increase the pump discharge.

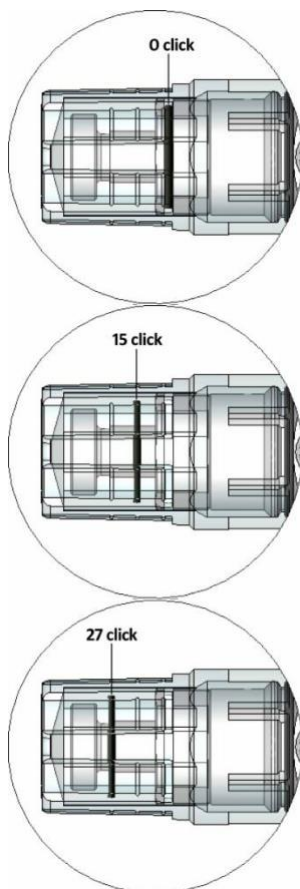

INCREMENTS	DISCHARGE / CYCLE
CLICK 0	39,00 mm ³
CLICK 1	37,23 mm ³
CLICK 2	35,47 mm ³
CLICK 3	33,70 mm ³
CLICK 4	31,93 mm ³
CLICK 5	30,16 mm ³
CLICK 6	28,40 mm ³
CLICK 7	26,63 mm ³
CLICK 8	24,86 mm ³
CLICK 9	23,10 mm ³
CLICK 10	21,33 mm ³
CLICK 11	19,56 mm ³
CLICK 12	17,79 mm ³
CLICK 13	16,03 mm ³
CLICK 14	14,26 mm ³
CLICK 15	12,49 mm ³
CLICK 16	10,73 mm ³
CLICK 17	8,96 mm ³
CLICK 18	7,19 mm ³
CLICK 19	5,42 mm ³
CLICK 20	3,66 mm ³
CLICK 21	1,89 mm ³
CLICK 22	0,12 mm ³
CLICK 23	0,00 mm ³
CLICK 24	0,00 mm ³
CLICK 25	0,00 mm ³
CLICK 26	0,00 mm ³
CLICK 27	0,00 mm ³

Modification of indicated specifications and design reserved

FREQUENCY GENERATOR ADJUSTMENT – AIR PRESSURE 6 bar (90 psi)

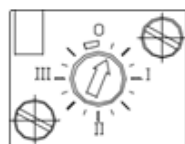

66 strokes/minute

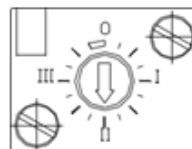

4 strokes/minute

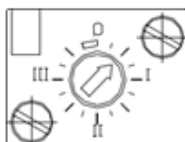

37 strokes/minute

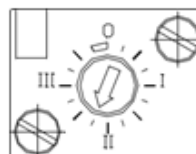

3 strokes/minute

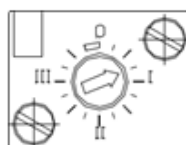

21 strokes/minute

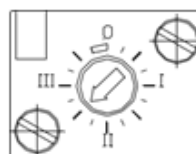

2.5 strokes/minute

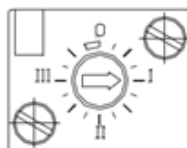

13 strokes/minute

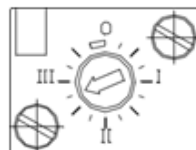

2 strokes/minute

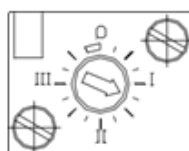

10 strokes/minute

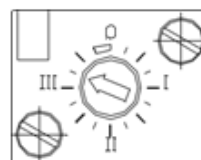

1 strokes/minute

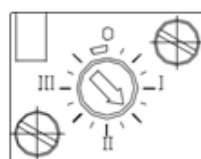

6 strokes/minute

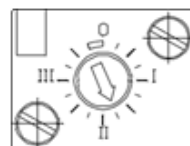

5 strokes/minute

Modification of indicated specifications and design reserved

With the air pressure 5 bar (75 psi) the values have to be increased of about 7 %.
With the air pressure 7 bar (105 psi) the values have to be decreased of about 4 %.
With the air pressure 8 bar (120 psi) the values have to be decreased of about 8 %.

COAXIAL FEEDING LINES

All lube tools are supplied with 5 m of coaxial hoses already assembled in the base of the pneumatic pumps. The outside nylon hoses have a diameter of 6 mm and the inside nylon hoses have a diameter of 2.5 mm. The inside hoses are 500 mm longer than the outside hoses because have to be join to the nozzle, while the outside hoses have to be joined to the straight adaptors. On request is possible to supply more longer hoses (up to 10 m) and/or special covering.

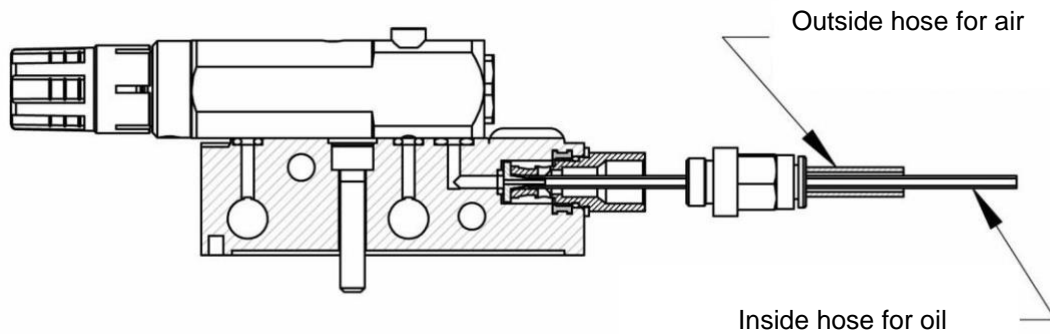

TERMINAL TUBES WITH NOZZLE

The end tubes with nozzle have an overall length of 300 mm that can be reduced cutting the steel tube or removing parts of the loc-line.

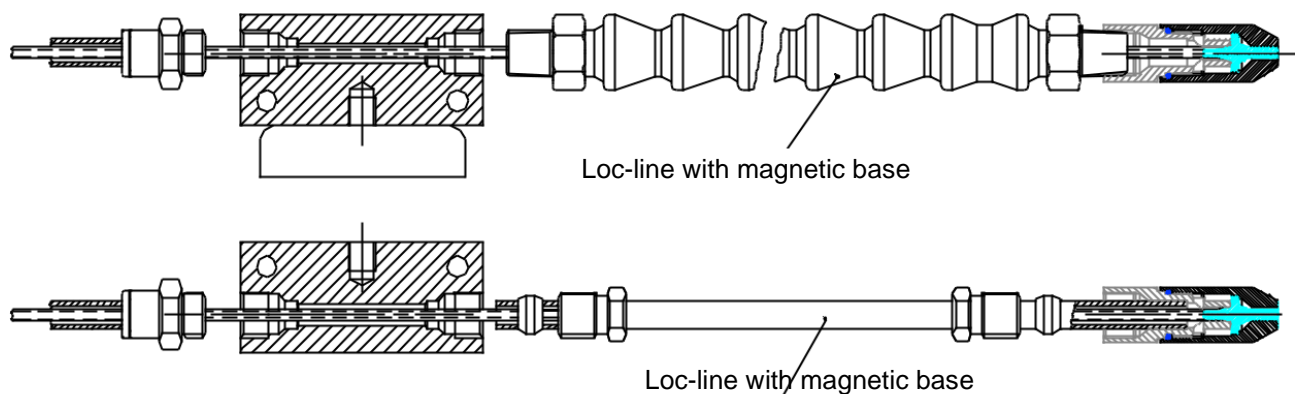

Modification of indicated specifications and design reserved

LUBETOOLS UCGF WITH FREQUENCY GENERATOR

The inside pneumatic circuit goes direct to the air feeding lines and to the pumps (through the frequency generator). When the solenoid valve is energized the pumps can cycle (adjustable with the frequency generator) from 66 cycles/min. up to 1 cycle/min and the air is sent continuously to the tool.

The solenoid valve has to be energized before the tool will begin to machine and shut down when the tool will finish to machine.

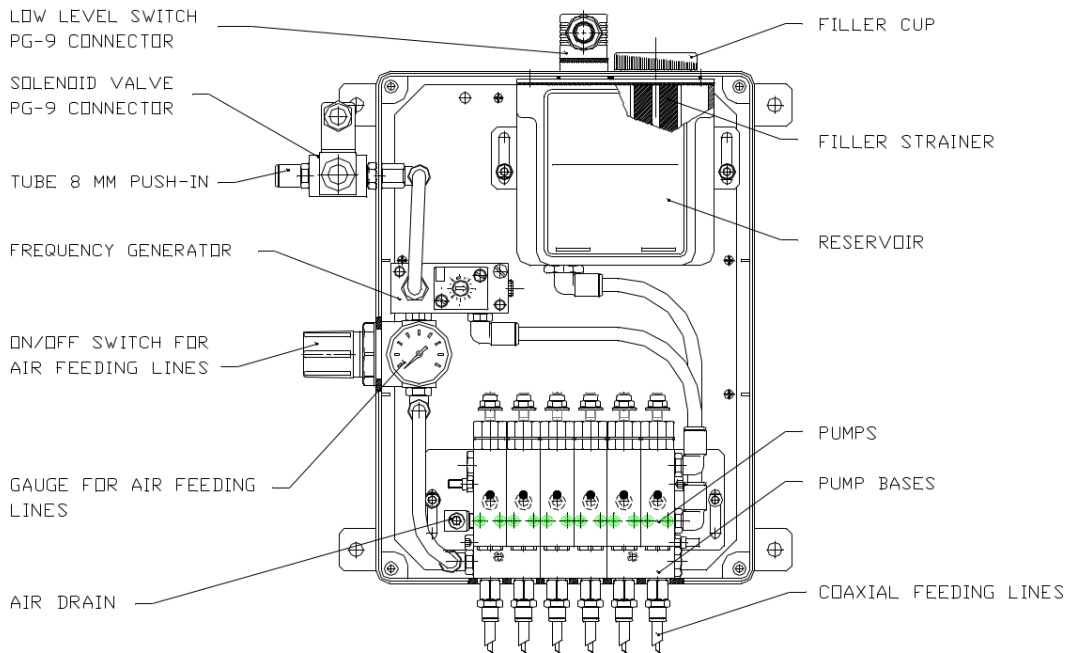

TECHNICAL SPECIFICATIONS

Discharge	from 0 mm ³ up to 39 mm ³ /stroke	Lubricant	oil max. 800 cSt 40°C
Number of pump units	From 1 up to 6	Box	ABS with transparent front door
Strokes	from 66/s up to 1/min.	Solenoid valve	24 V DC, 24 V AC, 115 V AC, 230 V AC
Reservoir	nylon, 1.2 l	Low level switch	1 A, 250 V AC, 200 V DC, 50 W

ORDERING CODES

CODE	TYPE	NUMBER OF PUMPING UNITS
1700000	UCGF – 1	1
1700001	UCGF – 2	2
1700002	UCGF – 3	3
1700003	UCGF – 4	4
1700004	UCGF – 5	5
1700005	UCGF – 6	6

ORDERING CODES FOR SOLENOID VALVE COILS

1146601	1146602	1146603	1146604
24V DC	115 V AC	230 V AC	24V AC

Modification of indicated specifications and design reserved

LUBETOOLS UCGF-SE, WITH FREQUENCY GENERATOR

LUBETOOLS UCGF-SE IS THE SAME AS UCGF, BUT WITHOUT SOLENOID VALVE

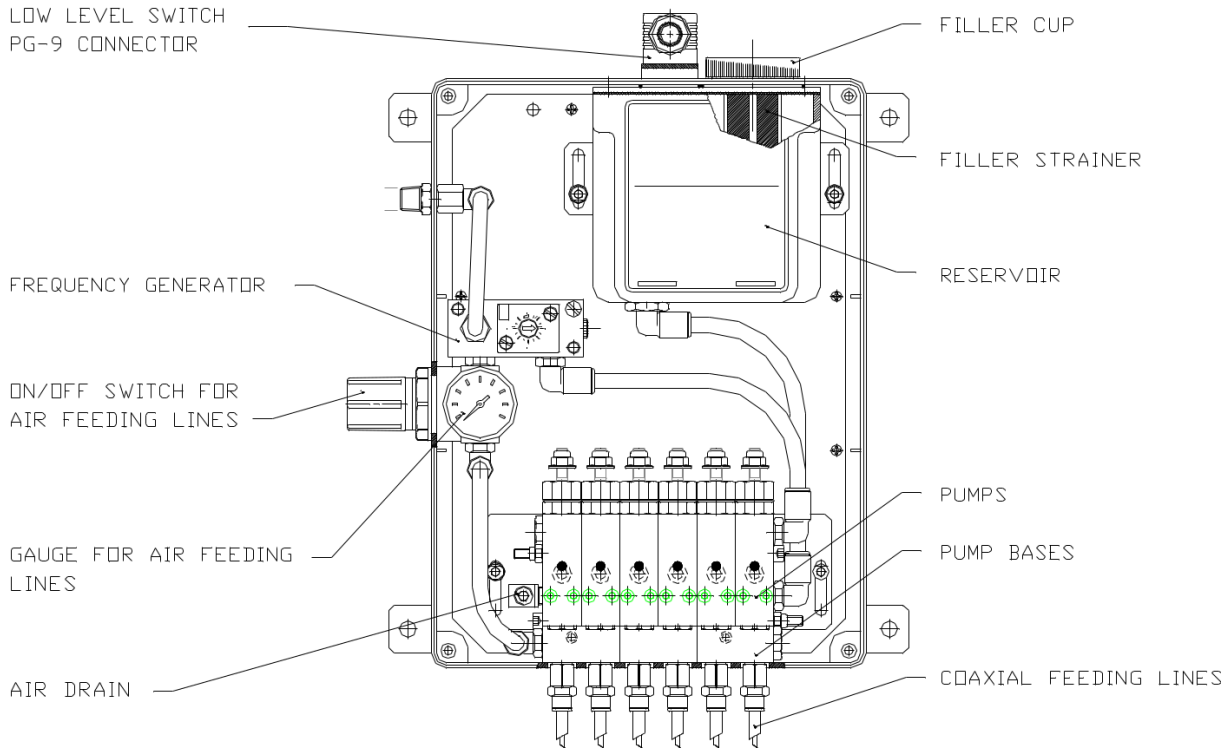

TECHNICAL SPECIFICATIONS

Dose	from 0 mm ³ to 39 mm ³ /stroke	Lubricant	oil max. 800 cSt 40°C
Pumps number	from 1 to 6	Box	ABS with transparent front door
Strokes	from 66/s to 1/min.	Low level switch	1 A, 250 V AC, 200 V DC, 50 W
Reservoir	nylon, 1.2 L		

ORDERING CODES

CODE	TYPE	PUMPS NUMBER
1700090	UCGF-SE – 1	1
1700091	UCGF-SE – 2	2
1700092	UCGF-SE – 3	3
1700093	UCGF-SE – 4	4
1700094	UCGF-SE – 5	5
1700095	UCGF-SE – 6	6

Modification of indicated specifications and design reserved

LUBETOOLS UCSG, WITHOUT FREQUENCY GENERATOR

The UCSG types need an external drive to adjust the frequency at which the pumps cycle. The inside pneumatic circuit goes direct to the air feeding lines and to the pumps. When the solenoid valve is energized the pumps can cycle 1 time and air is sent continuously to the tools. To have another pump cycle the solenoid valve have to be deenergized and after energized (minimum pause time is 0.5 seconds).

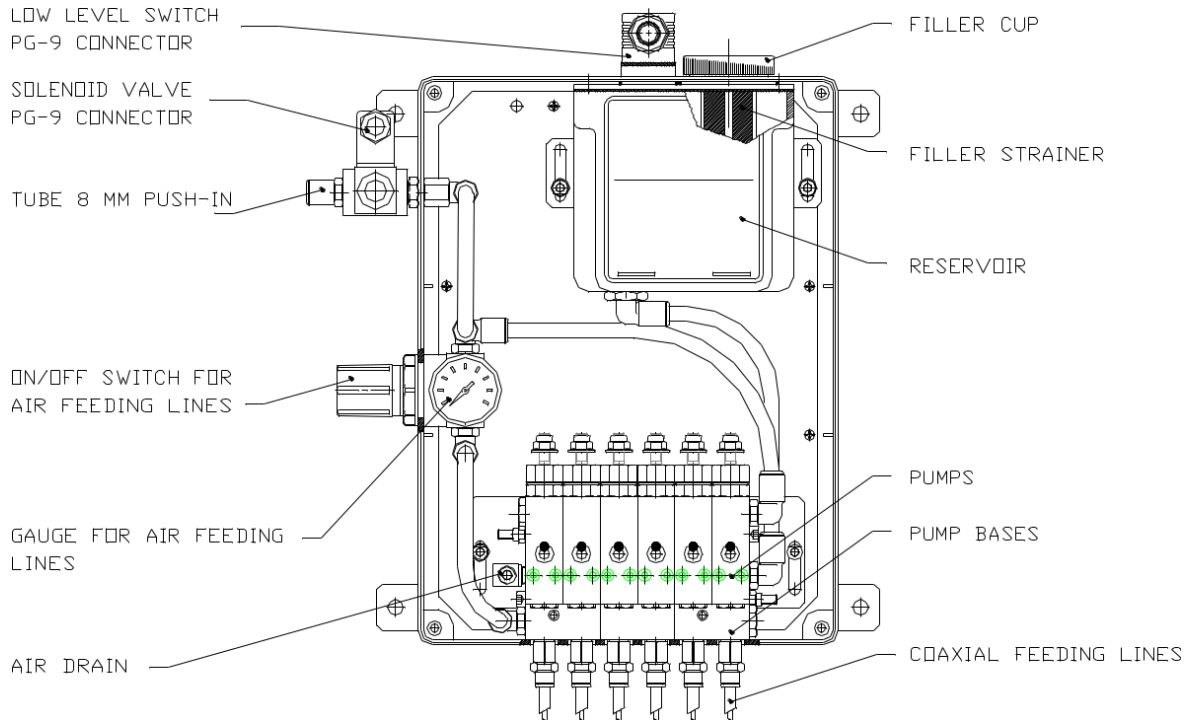

TECHNICAL SPECIFICATIONS

Dose	from 0 mm ³ up to 39 mm ³ /stroke	Lubricant	oil max. 800cSt 40°C
Number of pumping units	from 1 up to 6	Box	ABS with transparent front door
Strokes	from 66/s up to 1/min.	Solenoid valve	24 V DC, 24 V AC, 115 V AC, 230 V AC
Reservoir	nylon, 1.2 l	Low level switch	1 A, 250 V AC, 200 V DC, 50 W

ORDERING CODES

CODE	TYPE	NUMBER OF PUMPING UNITS
1700010	UCSG-1	1
1700011	UCSG-2	2
1700012	UCSG-3	3
1700013	UCSG-4	4
1700014	UCSG-5	5
1700015	UCSG-6	6

CODES TO ORDER SOLENOID VALVE COILS

1146601	1146602	1146603	1146604
24V DC	115V AC	230V AC	

Modification of indicated specifications and design reserved

LUBETOOLS UCSG-SE, WITHOUT FREQUENCY GENERATOR

LUBETOOLS UCSG-SE IS THE SAME AS UCSG, BUT SOLENOID VALVE IS NOT INCLUDED

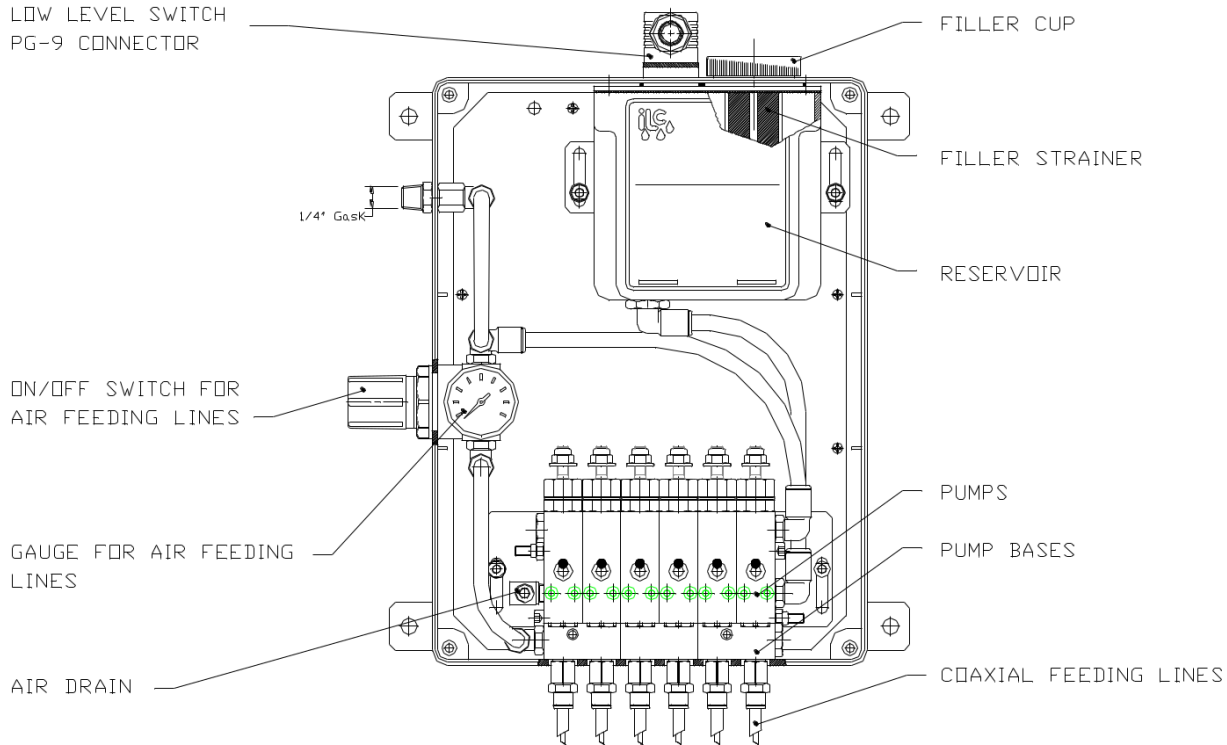

THE TECHNICAL SPECIFICATIONS

Dose	from 0 mm ³ up to 39 mm ³ /stroke	Lubricant	oil max. 800 cSt 40°C
Number of pumping units	from 1 to 6	Box	ABS with transparent front door
Strokes	from 66/s to 1/min.	MIN. level signal.	1 A, 250 V AC, 200 V DC, 50 W
Reservoir	nylon, 1.2 L		

ORDERING CODES

CODE	TYPE	NUMBER OF PUMPING UNITS
1700100	UCSG-SE – 1	1
1700101	UCSG-SE – 2	2
1700102	UCSG-SE – 3	3
1700103	UCSG-SE – 4	4
1700104	UCSG-SE – 5	5
1700105	UCSG-SE – 6	6

Modification of indicated specifications and design reserved

DIMENSIONAL DRAWING - UCGF, UCSG

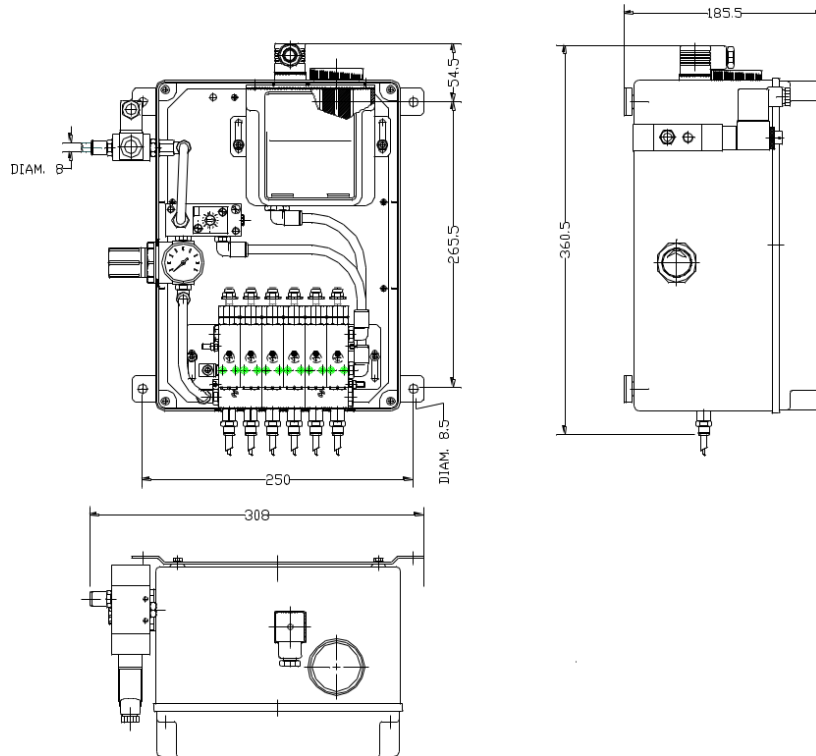

DIMENSIONAL DRAWING - UCGF - SE, UCSG - SE

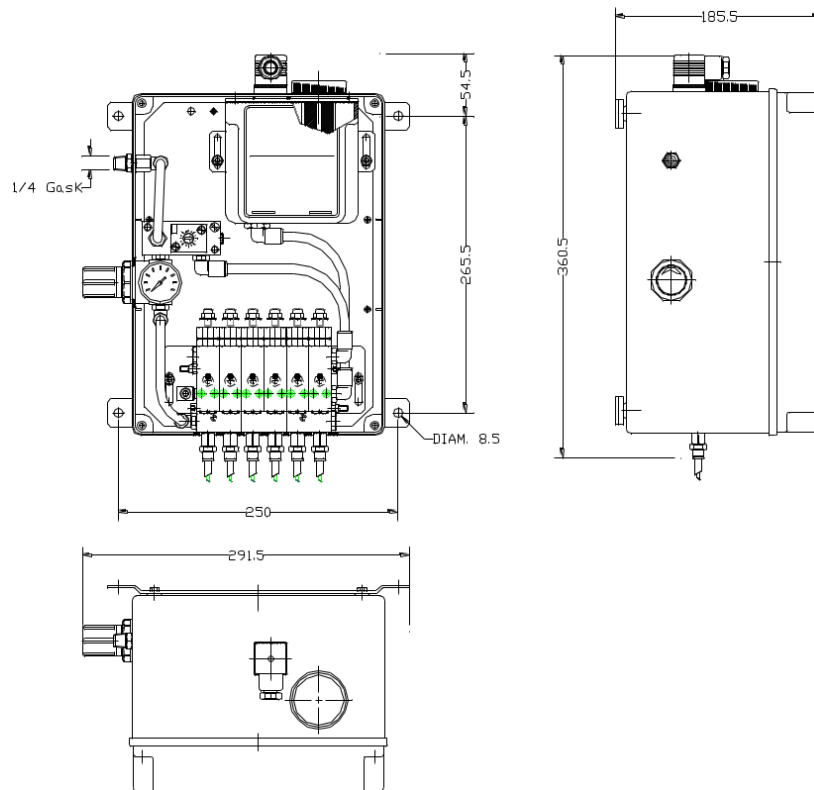

Modification of indicated specifications and design reserved

LUBETOOLS AGGF-SE, WITH FREQUENCY GENERATOR. CABINET, SOLENOID VALVE, AIR REGULATOR AND MANOMETER ARE NOT INCLUDED

AGGF is the same as UCGF, but without box, solenoid valve and air regulator with gauge. The air must be supplied by using an external solenoid valve and the pump cycles can be controlled by the frequency generator. The air pressure leading to the tool can be adjusted by using a manual valve.

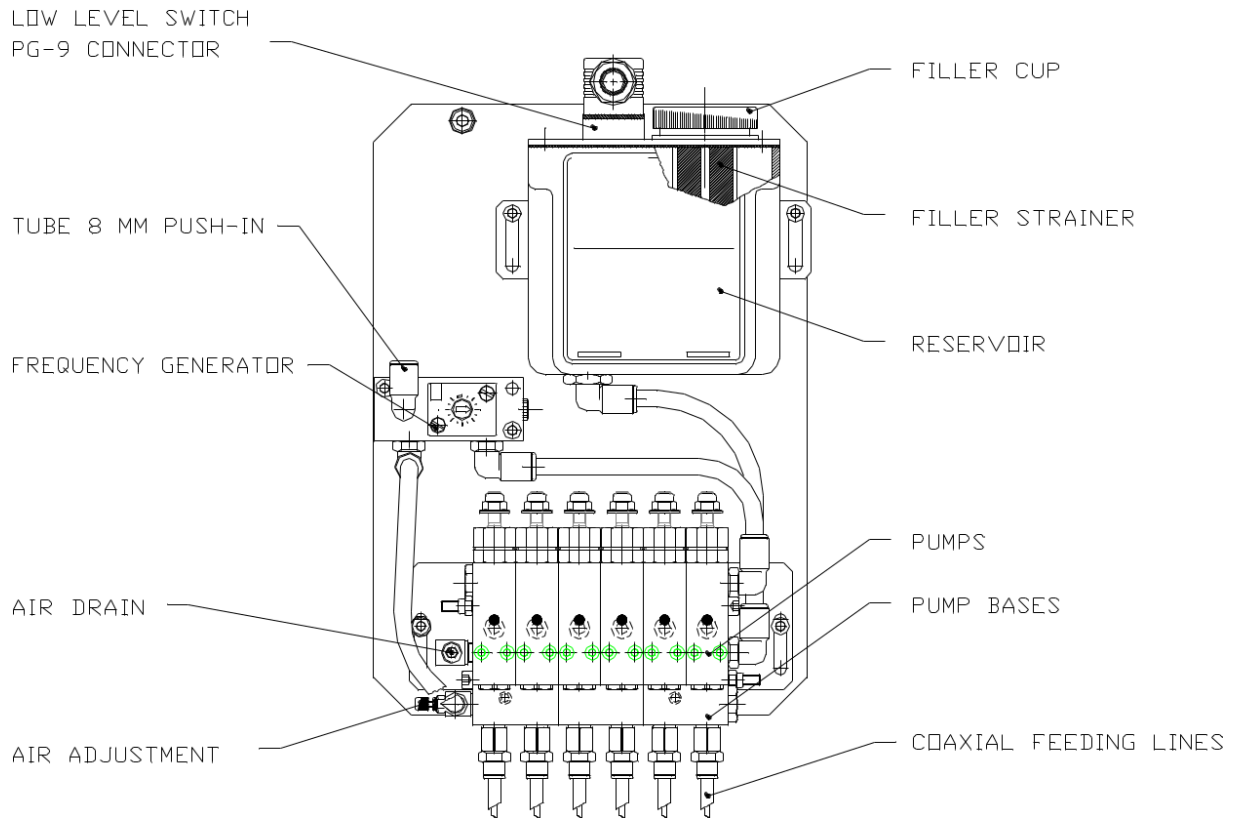

TECHNICAL SPECIFICATIONS

Dose	from 0 mm ³ to 39 mm ³ /stroke	Lubricant	oil max. 800 cSt 40°C
Number of pumping units	from 1 up to 6	Low level switch	1 A, 250 V AC, 200 V DC, 50 W
Strokes	from 66/s to 1/min.	Reservoir	nylon, 1.2 L

CODES FOR ORDER

CODE	TYPE	PUMPS NUMBER
1700020	AGGF-SE -1	1
1700021	AGGF-SE -2	2
1700022	AGGF-SE -3	3
1700023	AGGF-SE -4	4
1700024	AGGF-SE -5	5
1700025	AGGF-SE -6	6

Modification of indicated specifications and design reserved

LUBETOOLS AGGF, WITH FREQUENCY GENERATOR AND SOLENOID VALVE. CABINET, AIR REGULATOR AND MANOMETER ARE NOT INCLUDED

LUBETOOLS AGGF IS THE SAME AS AGGF-SE, BUT WITH SOLENOID VALVE

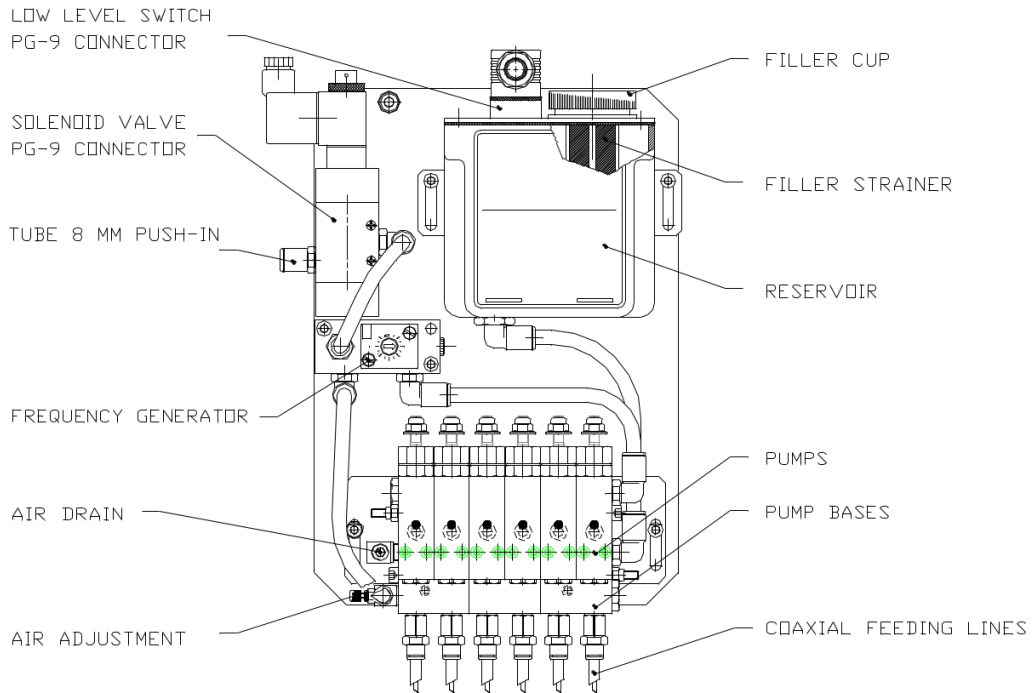

TECHNICAL SPECIFICATIONS

Dose	from 0 mm ³ to 39mm ³ /stroke	Lubricant	oil max. 800 cSt 40°C
Number of pumping units	from 1 to up to 6	Solenoid valve	24 V DC, 24 V AC, 115 V AC, 230 V AC
Strokes	from 66/s to 1/min.	Low level switch	1 A, 250 V AC, 200 V DC, 50 W
Reservoir	nylon, 1.2 l		

ORDERING CODES

CÓDE	TYPE	PUMPS NUMBER
1700060	AGGF-1	1
1700061	AGGF-2	2
1700062	AGGF-3	3
1700063	AGGF-4	4
1700064	AGGF-5	5
1700065	AGGF-6	6

ORDERING CODES FOR SOLENOID COILS

1146601	1146602	1146603	1146604
24V DC	115V AC	230V AC	24V AC

Modification of indicated specifications and design reserved

LUBETOOLS AGSG – SE, WITHOUT FREQUENCY GENERATOR, BOX, SOLENOID VALVE AND AIR REGULATOR WITH MANOMETER

AGSG is the same as UCSG, but without box, solenoid valve and air regulator with gauge. The air must be supplied by using an external solenoid valve. The air pressure leading to the tool can be adjusted by using a manual valve. The air can be transported into the nozzle and into the pump by the same tube, in this case the air will flow to the nozzle continuously. If it is necessary to supply the air into the nozzle continuously, it is necessary to have two separate lines.

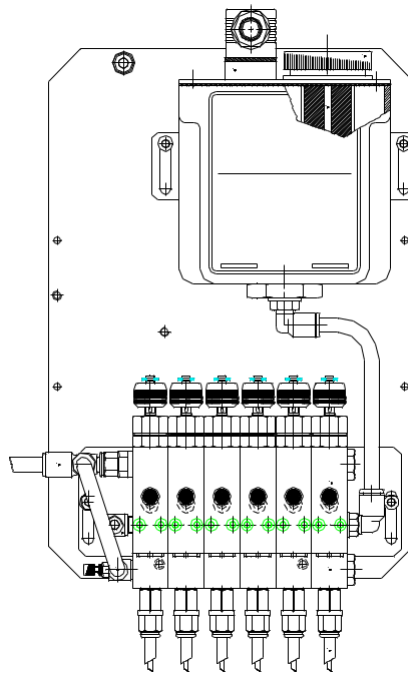

TECHNICAL SPECIFICATIONS

Dose	from 0 mm ³ to 39 mm ³ /stroke	Lubricant	oil max. 800 cSt 40°C
Number of pumping units	from 1 up to 6	Low level switch	1 A, 250 V AC, 200 V DC, 50 W
Strokes	from 66/s up to 1/min.	Reservoir	nylon, 1.2 L

ORDERING CODES

CODE	TYPE	PUMPS NUMBER
1700030	AGSG-SE-1	1
1700031	AGSG-SE -2	2
1700032	AGSG-SE -3	3
1700033	AGSG-SE -4	4
1700034	AGSG-SE -5	5
1700035	AGSG-SE -6	6

Modification of indicated specifications and design reserved

LUBETOOLS AGSG WITH SOLENOID VALVE, FREQUENCY GENERATOR. CABINET, AIR REGULATOR AND MANOMETER ARE NOT INCLUDED

LUBETOOLS AGGF IS THE SAME AS AGSG-SE, BUT SOLENOID VALVE IS INCLUDED

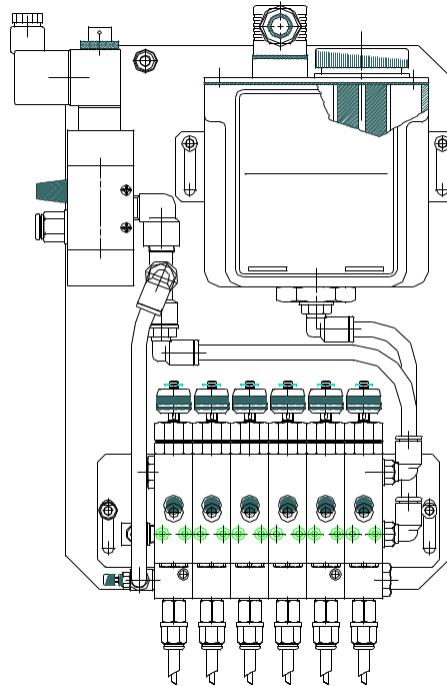

THE TECHNICAL SPECIFICATIONS

Dose	from 0 mm ³ to 39 mm ³ /stroke	Lubricant	oil max. 800cSt 40°C
Pumps number	from 1 up to 6	Solenoid valve	24 V DC, 24 V AC, 115 V AC, 230 V AC
Strokes	from 66/s up to 1/min.	MIN. level signalling	1 A, 250 V AC, 200 V DC, 50 W
Reservoir	nylon, 1.2 l		

CODES FOR ORDER

CODE	TYPE	PUMPS NUMBER
1700180	AGSG-1	1
1700181	AGSG-2	2
1700182	AGSG-3	3
1700183	AGSG-4	4
1700184	AGSG-5	5
1700185	AGSG-6	6

CODES TO ORDER SOLENOID VALVE COILS

1146601	1146602	1146603	1146604
24V DC	115V AC	230V AC	24V AC

Modification of indicated specifications and design reserved

DIMENSIONAL DRAWING - AGGF-SE, AGSG-SE

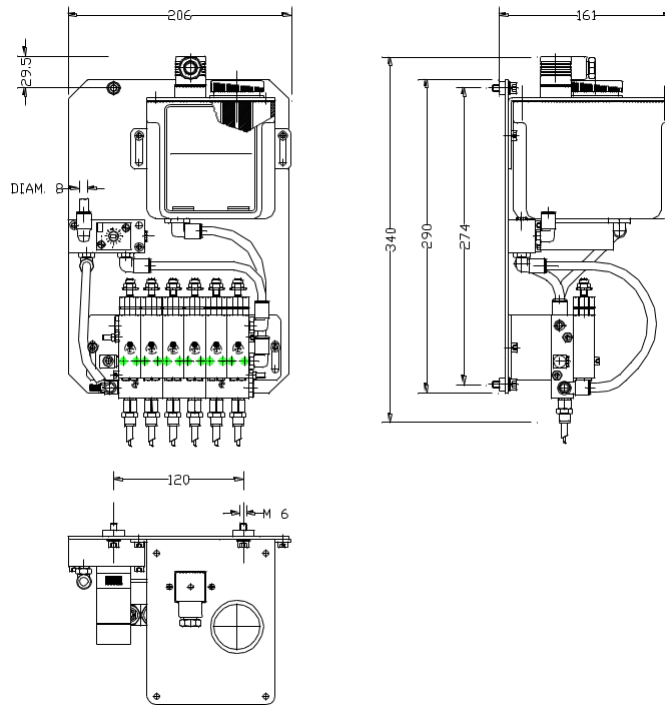

DIMENSIONAL DRAWING - AGGF, AGSG

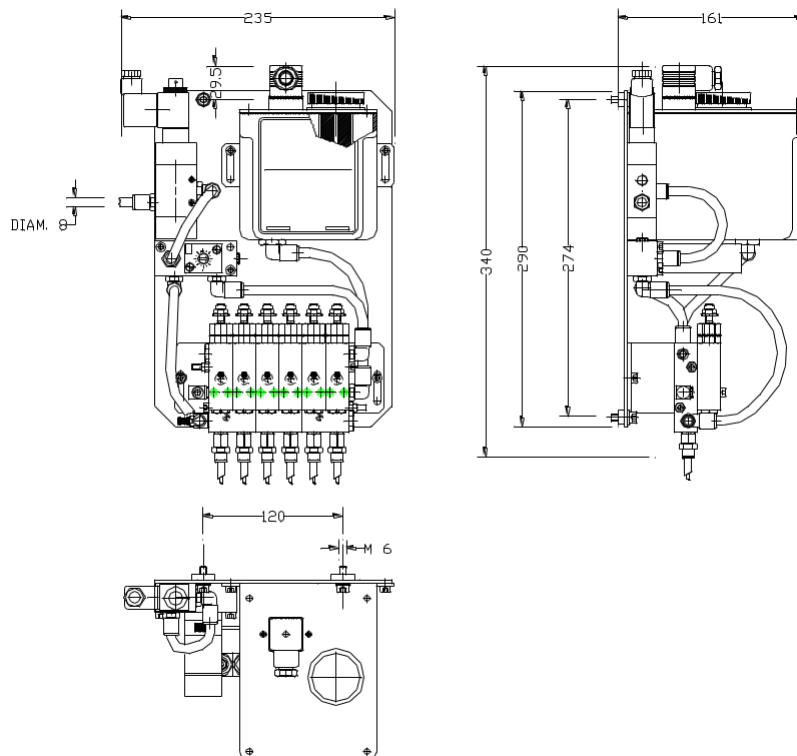

Modification of indicated specifications and design reserved

LUBETOOLS MINI.GF SYSTEMS, WITH FREQUENCY GENERATOR. CABINET, ELECTROMAGNETIC VALVE. SHUT-OFF COCK AND MANOMETER ARE NOT INCLUDED

These systems are similar to AGGF, but without the mounting plate. To install this type, it is necessary to use two anchor holes on the tank cover.

They are used for small machines where there is not enough space and costs need to be reduced. Air must be supplied via an external electromagnetic valve, the pump cycle can be set via a frequency generator. The air pressure directed to the tool can be regulated using a manual valve. The systems can be supplied with a 1.2 L, 2.2 L or 3.6 L reservoir equipped with a minimum oil level indicator.

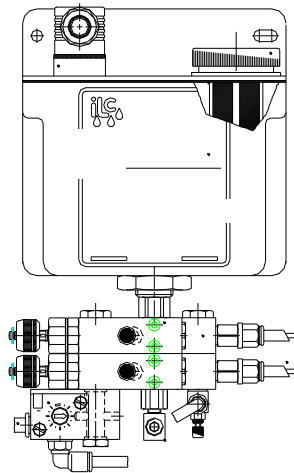

TECHNICAL SPECIFICATION

Dose	from 0 up to 39 mm ³ /stroke	Lubricant	oil max. 800cSt 40°C
Number of pumping units	from 1 up to 2	MIN. level signalling	1 A, 250 V AC, 200 V DC, 50 W
Strokes	from 66 up to 1/min.	Reservoir	plastic, 1.2, 2.2, 3.6 L

ORDERING CODES

CODE	TYPE	NUMBER OF PUMPING UNITS
1700040	MINI.GF – 1 / 1.2 Reservoir	1
1700041	MINI.GF – 2 / 1.2 Reservoir	2
1700042	MINI.GF – 1 / 2.2 Reservoir	1
1700043	MINI.GF – 2 / 2.2 Reservoir	2
1700044	MINI.GF – 1 / 3.6 Reservoir	1
1700045	MINI.GF – 2 / 3.6 Reservoir	2

Modification of indicated specifications and design reserved

LUBETOOLS MINI.GF-EL WITH FREQUENCY GENERATOR AND SOLENOID VALVE. CABINET, SHUT-OFF COCK AND MANOMETER ARE NOT INCLUDED.

LUBETOOLS MINI.GF-EL IS THE SAME AS MINI.GF, BUT EQUIPPED BY SOLENOID VENTIL

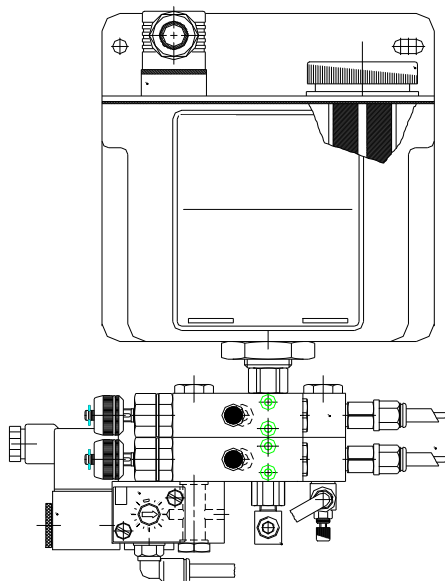

TECHNICAL SPECIFICATION

Dose	from 0 up to 39mm ³ /stroke	Lubricant	oil max. 800cSt 40°C
Number of pumping units	from 1 up to 2	Electromagnetic valve	24 V DC, 24 V AC, 115 V AC, 230 V AC
Strokes	from 66 up to 1/min.	MIN. level signalling	1 A, 250 V AC, 200 V DC, 50 W
Reservoir	plastic, 1.2 L or 2.2 L, 3.6 L		

ORDERING CODES

CODE	TYPE	NUMBER OF PUMPING UNITS
1700150	MINI.GF-EL – 1 / 1.2 L Reservoir	1
1700200	MINI.GF-EL – 2 / 1.2 L Reservoir	2
1700151	MINI.GF-EL – 1 / 2.2 L Reservoir	1
1700201	MINI.GF-EL – 2 / 2.2 L Reservoir	2
1700152	MINI.GF-EL – 1 / 3.6 L Reservoir	1
1700202	MINI.GF-EL – 2 / 3.6 L Reservoir	2

VOLTAGE OF SOLENOID VALVE COIL MUST BE INCLUDED IN ORDER FOR MICRO LUBRICATION CODE. CODE: 1146601 COIL 24V DC – CODE: 1146602 COIL 115V AC – CODE: 1146603 COIL 230V AC – CODE: 1146604 COIL 2 4V AC.

Modification of indicated specifications and design reserved

MINI.GF-EL – DIMENSION DRAWING

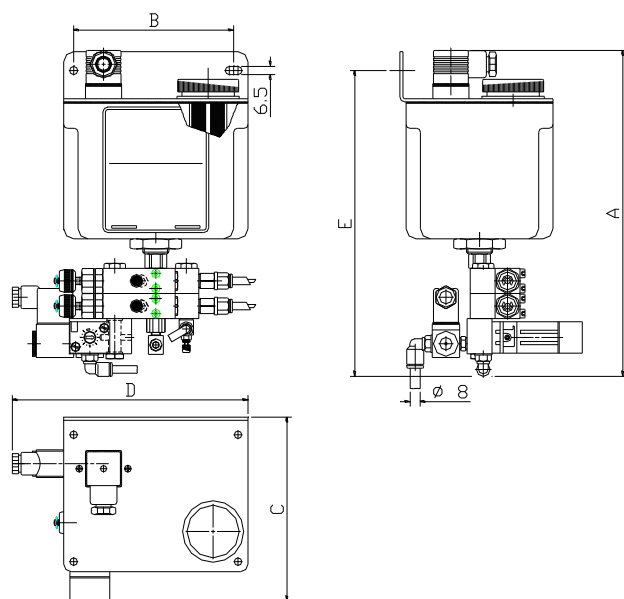

Code:	Tank	A mm	B mm	C mm	D mm	E mm
1700150	1.2 L	240	129	146	190	224
1700200	1.2 L	260	129	146	190	244
1700151	2.2 L	292	129	146	190	276
1700201	2.2 L	312	129	146	190	296
1700152	3.6 L	287	173	153	230	271

MINI.GF - DIMENSION DRAWING

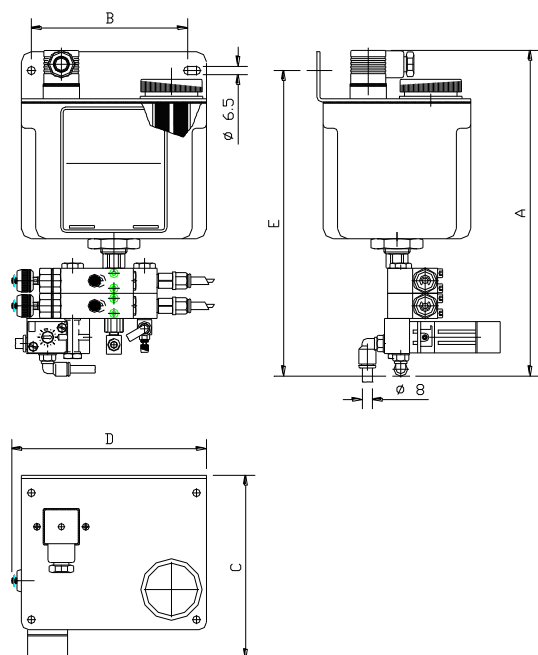

Code	Tank	A mm	B mm	C mm	D mm	E mm
1700040	1.2 L	260	129	147	155	244
1700041	1.2 L	280	129	147	155	264
1700042	2.2 L	312	129	147	155	296
1700043	2.2 L	332	129	147	155	316
1700044	3.6 L	307	173	153	230	291
1700045	3.6 L	327	173	153	230	311

Modification of indicated specifications and design reserved

LUBETOOLS MINI.SG, FREQUENCY GENERATOR, CABINET, SOLENOID VALVE AND SHUT-OFF COCK ARE NOT INCLUDED.

These systems are similar to AGSG, but without the mounting plate. To install this type, it is necessary to use two anchor holes on the tank cover.

These systems are applied for smaller machines where there is not enough space and the acquisition costs need to be reduced. They are supplied with a tank with a volume of 1.2 L, 2.2 L or 3.6 L equipped with a minimum oil level signal.

Air must be supplied through an external electromagnetic valve, the pressure of the air supplied to the tool can be adjusted using a manual valve. Air to the nozzle and to the pumping units can be transported through the same line. In this case, air will not flow continuously into the nozzle. If the air needs to be continuously supplied to the nozzle, two separate lines must be used.

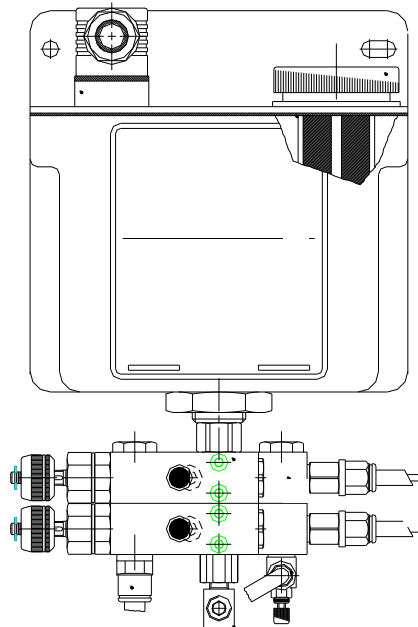

TECHNICAL SPECIFICATION

Dose	from 0 up to 39mm ³ /stroke	Lubricant	oil max. 800 cSt 40°C
Number of pumping units	from 1 up to 2	MIN. level signalling	1 A, 250 V AC, 200 V DC, 50 W
Strokes	from 66 up to 1/min.	Reservoir	plastic, 1.2, 2.2, 3.6 L

ORDERING CODES

CODE	TYPE	NUMBER OF PUMPING UNITS
1700050	MINI.SG – 1 / 1.2 L Reservoir	1
1700051	MINI.SG – 2 / 1.2 L Reservoir	2
1700052	MINI.SG – 1 / 2.2 L Reservoir	1
1700053	MINI.SG – 2 / 2.2 L Reservoir	2
1700054	MINI.SG – 1 / 3.6 L Reservoir	1
1700055	MINI.SG – 2 / 3.6 L Reservoir	2

Modification of indicated specifications and design reserved

LUBETOOLS MINI.SG – EL, WITH SOLENOID VALVE, FREQUENCY GENERATOR, CABINET. SHUT-OFF COCK, MANOMETER ARE NOT INCLUDED.

LUBETOOLS MINI.SG-EL IS THE SAME AS MINI.SG, BUT EQUIPPED WITH SOLENOID VALVE VENTIL

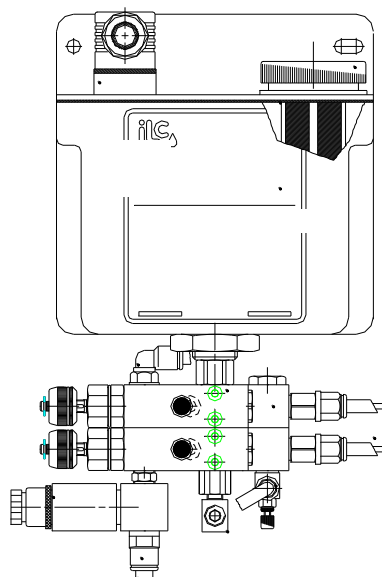

TECHNICAL SPECIFICATION

Dose	from 0 do 39mm ³ /stroke	Lubricant	oil max. 800 cSt 40°C
Number of pumping units	from 1 up to 2	Electromagnetic valve	24 V DC, 24 V AC, 115 V AC, 230 V AC
Strokes	from 66 up to 1/min.	MIN. level signalling	1 A, 250 V AC, 200 V DC, 50 W
Reservoir	plastic, 1.2, 2.2, 3.6 l		

ORDERING CODES

CODE	TYPE	NUMBER OF PUMPING UNITS
1700170	MINI.SG-EL – 1 / 1.2 L Reservoir	1
1700171	MINI.SG-EL – 2 / 1.2 L Reservoir	2
1700172	MINI.SG-EL – 1 / 2.2 L Reservoir	1
1700173	MINI.SG-EL – 2 / 2.2 L Reservoir	2
1700174	MINI.SG-EL – 1 / 3.6 L Reservoir	1
1700175	MINI.SG-EL – 2 / 3.6 L Reservoir	2

VOLTAGE OF SOLENOID VALVE COIL MUST BE INCLUDED IN ORDER FOR MICRO LUBRICATION CODE. CODE: 1146601 COIL 24V DC – CODE: 1146602 COIL 115V AC – CODE: 1146603 COIL 230V AC – CODE: 1146604 COIL 24V AC.

Modification of indicated specifications and design reserved

MINI.SG-EL - DIMENSION DRAWING

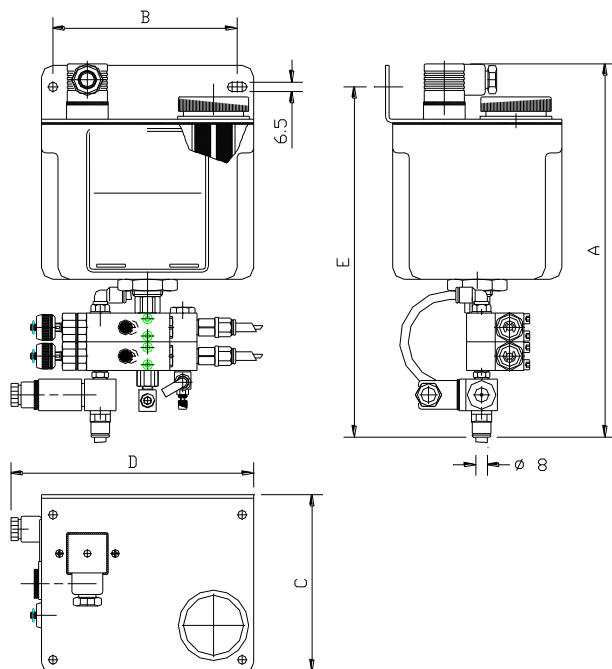

Code	Tank	A mm	B mm	C mm	D mm	E mm
1700170	1.2 L	240	129	123	170	224
1700171	1.2 L	260	129	123	170	244
1700172	2.2 L	292	129	123	170	276
1700173	2.2 L	312	129	123	170	296
1700174	3.6 L	287	173	135	230	271
1700175	3.6 L	307	173	135	230	291

MINI.SG – DIMENSION DRAWING

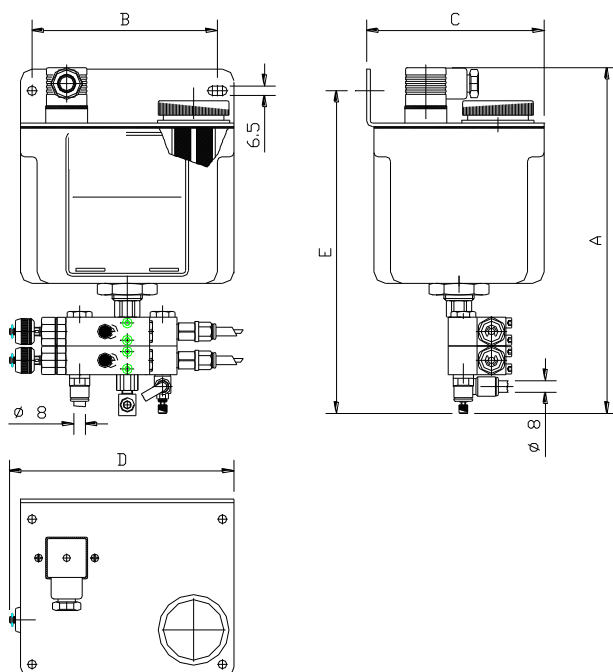

Code	Tank	A mm	B mm	C mm	D mm	E mm
1700050	1.2 L	220	129	123	155	204
1700051	1.2 L	240	129	123	155	224
1700052	2.2 L	272	129	123	155	256
1700053	2.2 L	292	129	123	155	276
1700054	3.6 L	215	173	135	230	251
1700055	3.6 L	235	173	135	230	271

Modification of indicated specifications and design reserved

LUBETOOLS MINI – GF – EL – SS, INSTALLED ON SPECIAL ASSEMBLING PLATE, WITH FREQUENCY GENERATOR, AIR REGULATOR AND SOLENOID VALVE. RESERVOIR, CABINET, SHUT-OFF COCK, MANOMETER ARE NOT INCLUDED.

SOLENOID VALVE (CODE: 114660) MUST BE ORDERED AS A SPECIAL ITEM WITH REQUIRED COIL VOLTAGE.

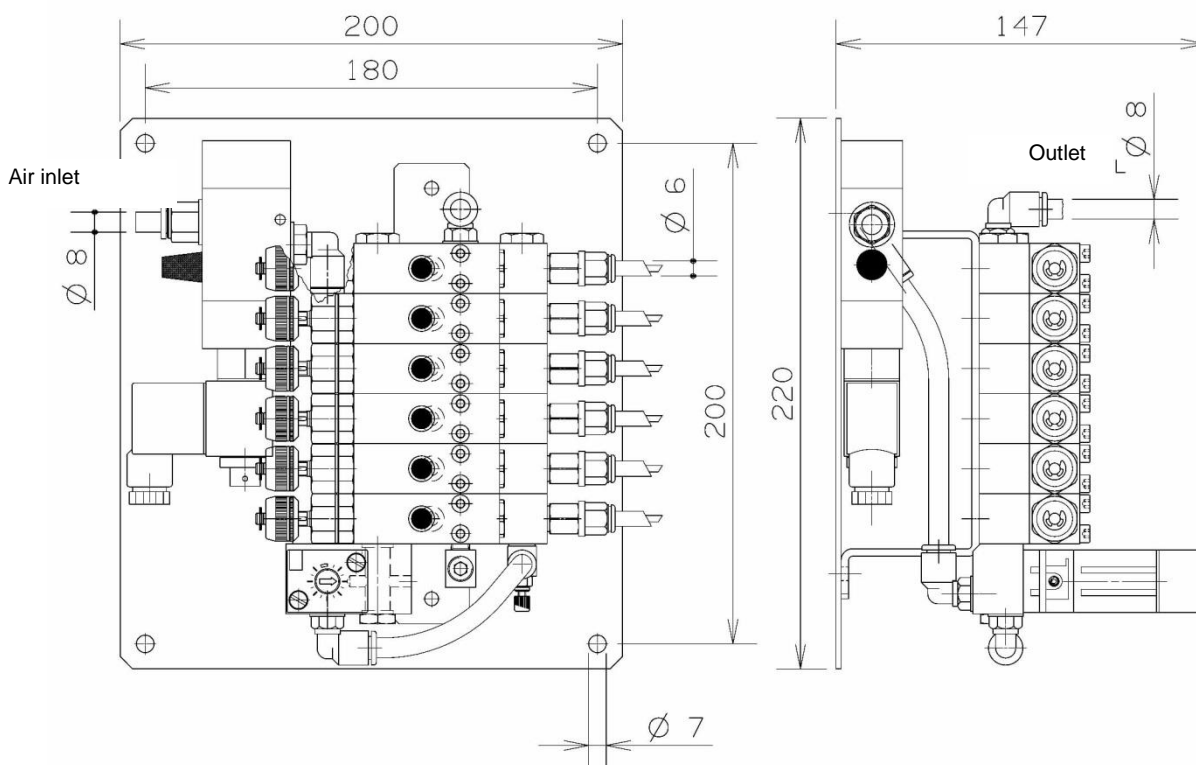

ORDERING CODES

CODE	TYPE	NUMBER OF PUMPING UNITS
1707161	MINI-GF-EL-1P-SS	1
1707162	MINI-GF-EL-2P-SS	2
1707163	MINI-GF-EL-3P-SS	3
1707164	MINI-GF-EL-4P-SS	4
1707165	MINI-GF-EL-5P-SS	5
1707166	MINI-GF-EL-6P-SS	6

VOLTAGE OF SOLENOID VALVE COIL MUST BE INCLUDED IN ORDER FOR MICRO LUBRICATION CODE. CODE: 1146601 COIL 24V DC – CODE: 1146602 COIL 115V AC – CODE: 1146603 COIL 230V AC – CODE: 1146604 COIL 2 4V AC.

Modification of indicated specifications and design reserved

LUBETOOLS MINI – 035 - WFG

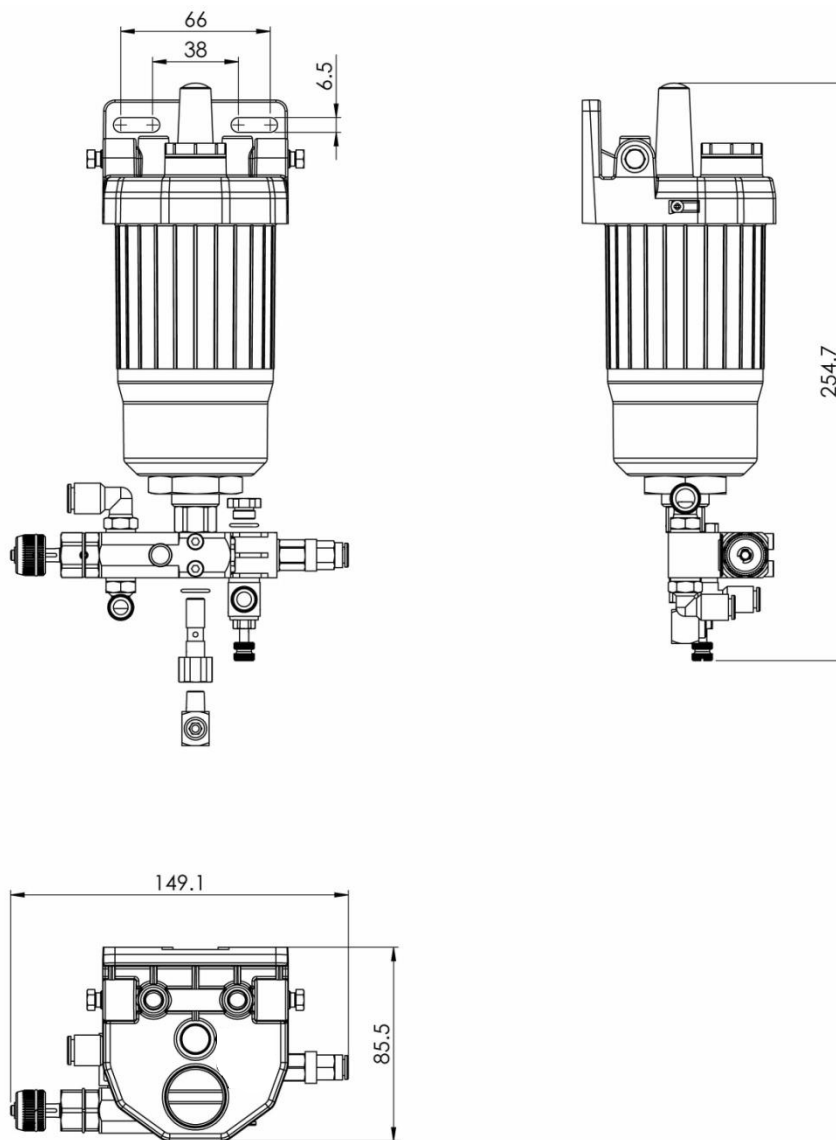

TECHNICAL SPECIFICATIONS

Dose	from 0 up to 39mm ³ /stroke	Lubricant	oil max. 800 cSt 40°C
Number of pumping units	1	Reservoir	plastic, 0.5 L

ORDERING CODE: 1700550

Modification of indicated specifications and design reserved

LUBETOOLS MINI – 035 – FG

LUBETOOLS MINI – 035 - FG is as MINI – 035 - WFG, BUT EQUIPPED BY FREQUENCY GENERATOR

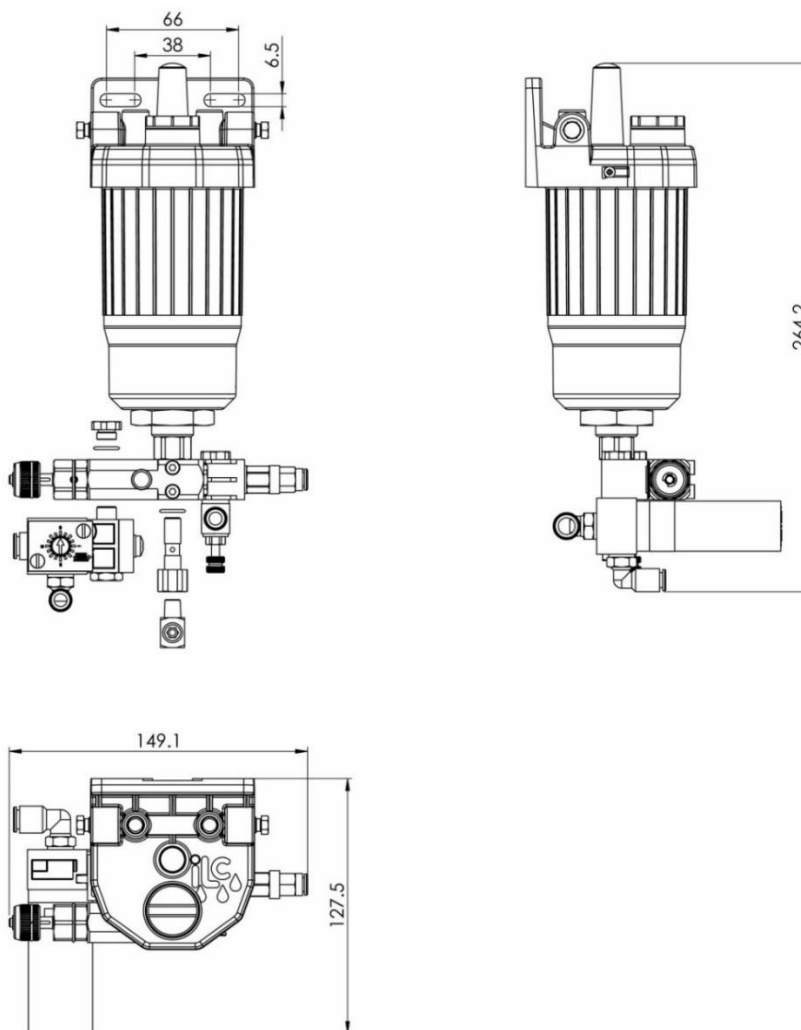

TECHNICAL SPECIFICATIONS

Dose	from 0 up to 39 mm ³ /stroke	Lubricant	Oil max. 800 cSt 40°C
Number of pumping units	1	Reservoir	plastic, 0.5 L

ORDERING CODE: 1700551

Modification of indicated specifications and design reserved

LUBETOOLS MC-EL WITH 1.2 L OR 2.2 L TANK, SOLENOID VALVE, FREQUENCY GENERATOR, METAL CASE AND CLOSING COCK WITH PRESSURE GAUGE

This type can also be supplied with a metal-sheathed coaxial power cable in lengths of 1, 2, 3, 4 or 5 meters.

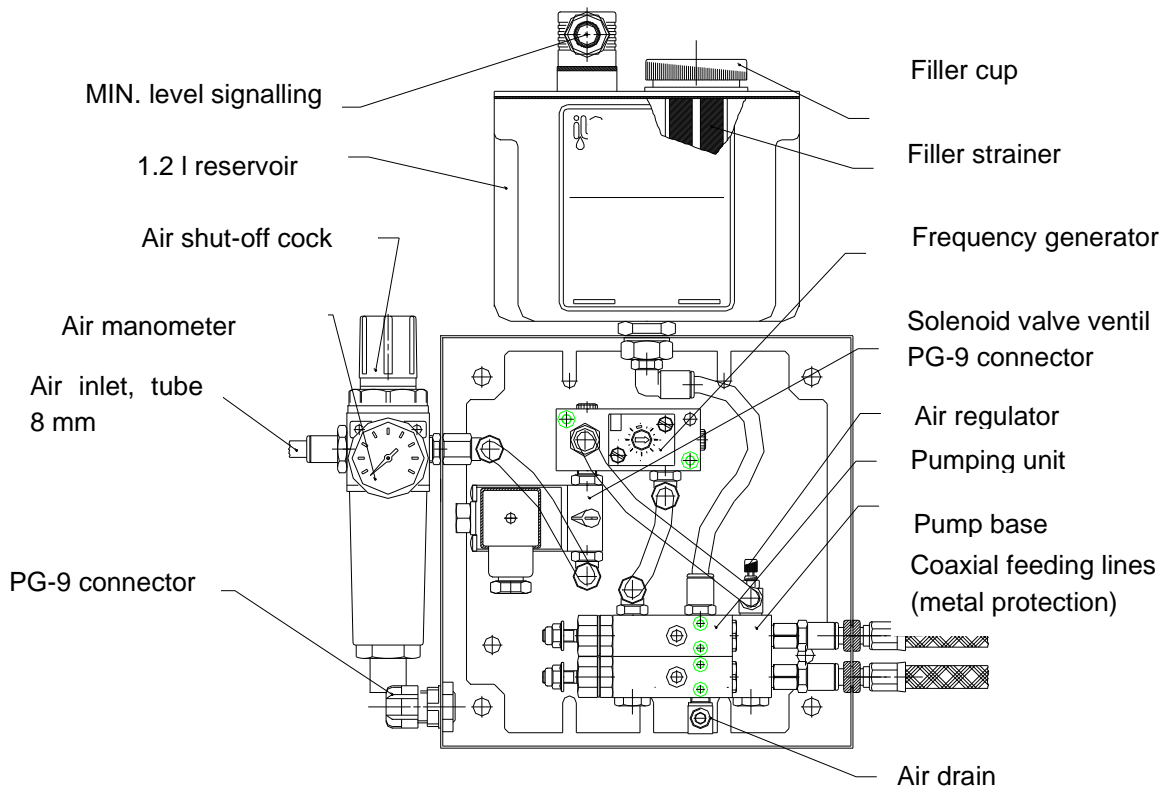

TECHNICAL SPECIFICATIONS

Dose	from 0 up to 39mm ³ /stroke	Lubricant	oil max. 800 cSt 40°C
Number of pump. units	from 1 up to 2	Electromagnetic valve	24 V DC, 24 V AC, 115 V AC, 230 V AC
Strokes	from 66 up to 1/min.	MIN. level signalling	1 A, 250 V AC, 200 V DC, 50 W
Reservoir	plastic, 1.2 l or 2.2 l		

CODE	TYPE	NUMBER OF PUMPING UNITS
1700501	MC-EL – 1 / 1.2 L Reservoir	1
1700502	MC-EL – 2 / 1.2 L Reservoir	2
1700511	MC-EL – 1 / 2.2 L Reservoir	1
1700512	MC-EL – 2 / 2.2 L Reservoir	2

VOLTAGE OF SOLENOID VALVE COIL MUST BE INCLUDED IN ORDER FOR MICRO LUBRICATION CODE. CODE: 1146601 COIL 24V DC – CODE: 1146602 COIL 115V AC – CODE: 1146603 COIL 230V AC – CODE: 1146604 COIL 24V AC.

Modification of indicated specifications and design reserved

MC-EL - DIMENSION DRAWING

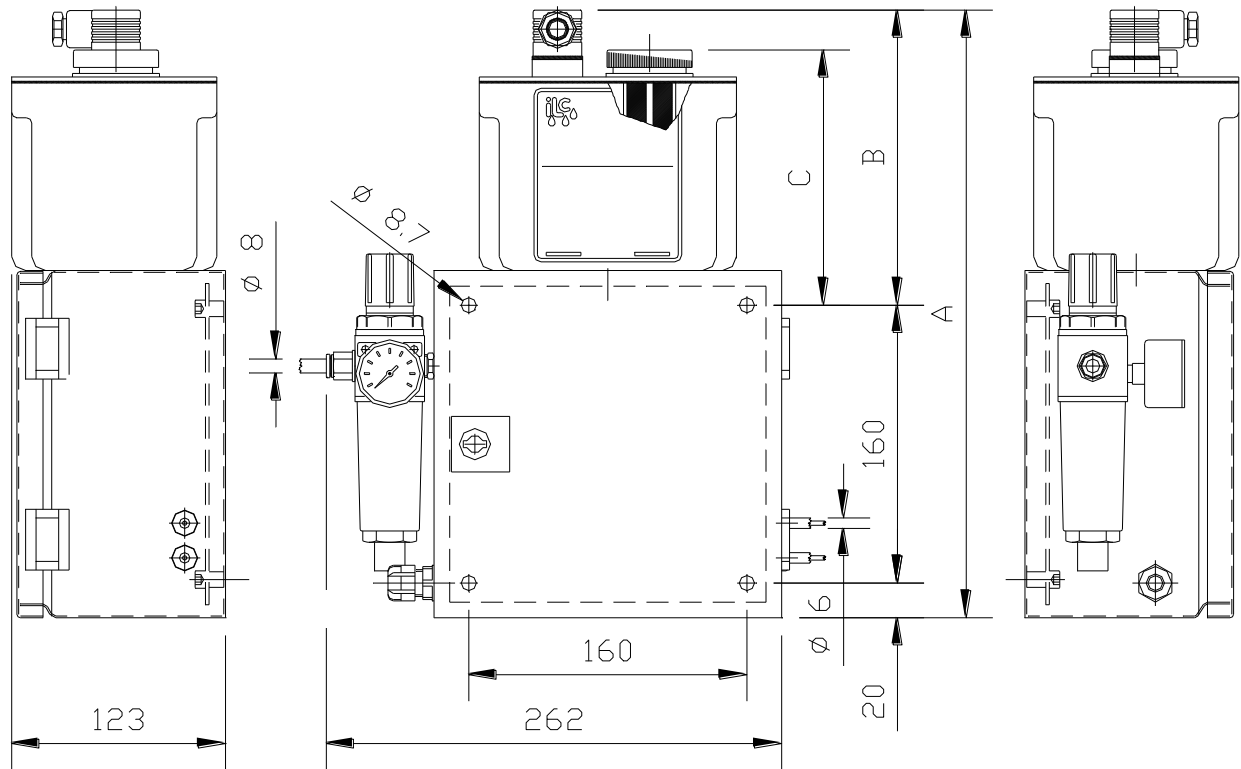

RESERVOIR	A mm	B mm
1.2 L	350	170
2.2 L	402	222

Modification of indicated specifications and design reserved

LUBETOOLS MC – EL – P

LUBETOOLS MC – EL – P IS PLACED IN A METAL BOX, WITHOUT TANK BUT INCLUDING FREQUENCY GENERATOR, AIR REGULATOR WITH PRESSURE GAUGE AND SOLENOID VALVE, FOR 3 UP TO 7 WORKING UNITS.

SOLENOID VALVE (CODE: 114660) MUST BE ORDERED AS A SPECIAL ITEM WITH REQUIRED COIL VOLTAGE.

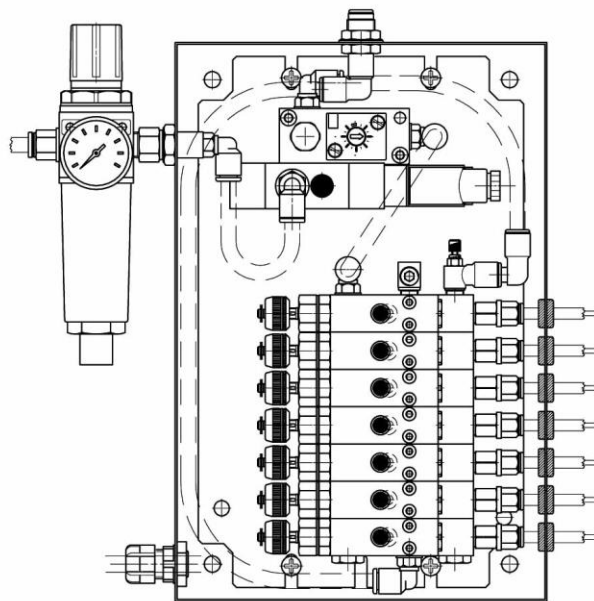

TECHNICAL SPECIFICATION

Dose	from 0 up to 39 mm ³ /stroke	Lubricant	oil max. 800 cSt 40°C
Number of pumps	from 3 up to 7	Cabinet	metal
Strokes	from 66 to 1/min.	Electromagnetic valve	24 V DC, 24 V AC, 115 V AC, 230 V AC
Reservoir	must be specified as a separate item	MIN. level signalling	1 A, 250 V AC, 200 V DC, 50 W

ORDERING CODES

CODE	TYPE	NUMBER OF PUMPS
1707053	MC-EL-3P	3
1707054	MC-EL-4P	4
1707055	MC-EL-5P	5
1707056	MC-EL-6P	6
1707057	MC-EL-7P	7

VOLTAGE OF SOLENOID VALVE COIL MUST BE INCLUDED IN ORDER FOR MICRO LUBRICATION CODE. CODE: 1146601 COIL 24V DC – CODE: 1146602 COIL 115V AC – CODE: 1146603 COIL 230V AC – CODE: 1146604 COIL 2 4V AC.

Modification of indicated specifications and design reserved

MC-EL-P - DIMENSION DRAWING

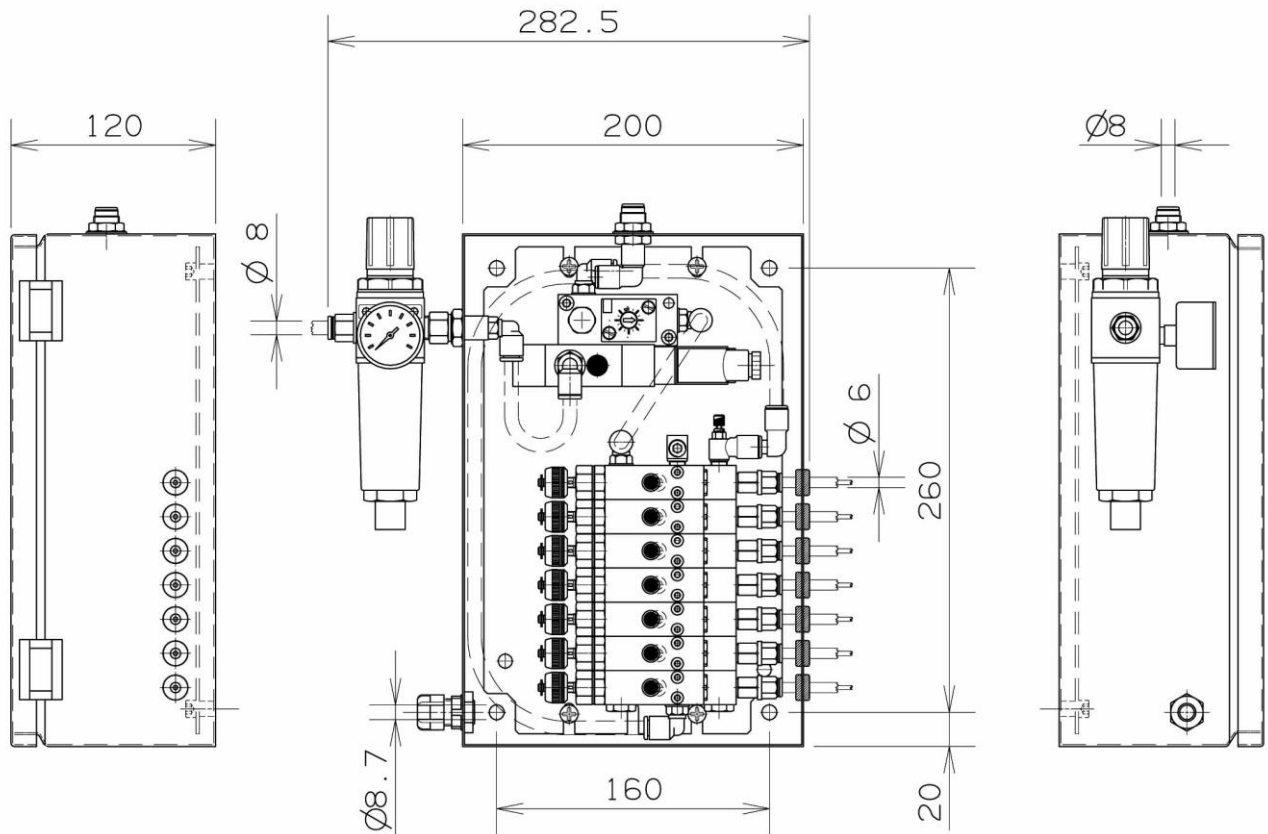

Modification of indicated specifications and design reserved

**EXAMPLE OF LUBETOOLS MICRO LUBRICATION FOR SHEETS
up to 800mm width**

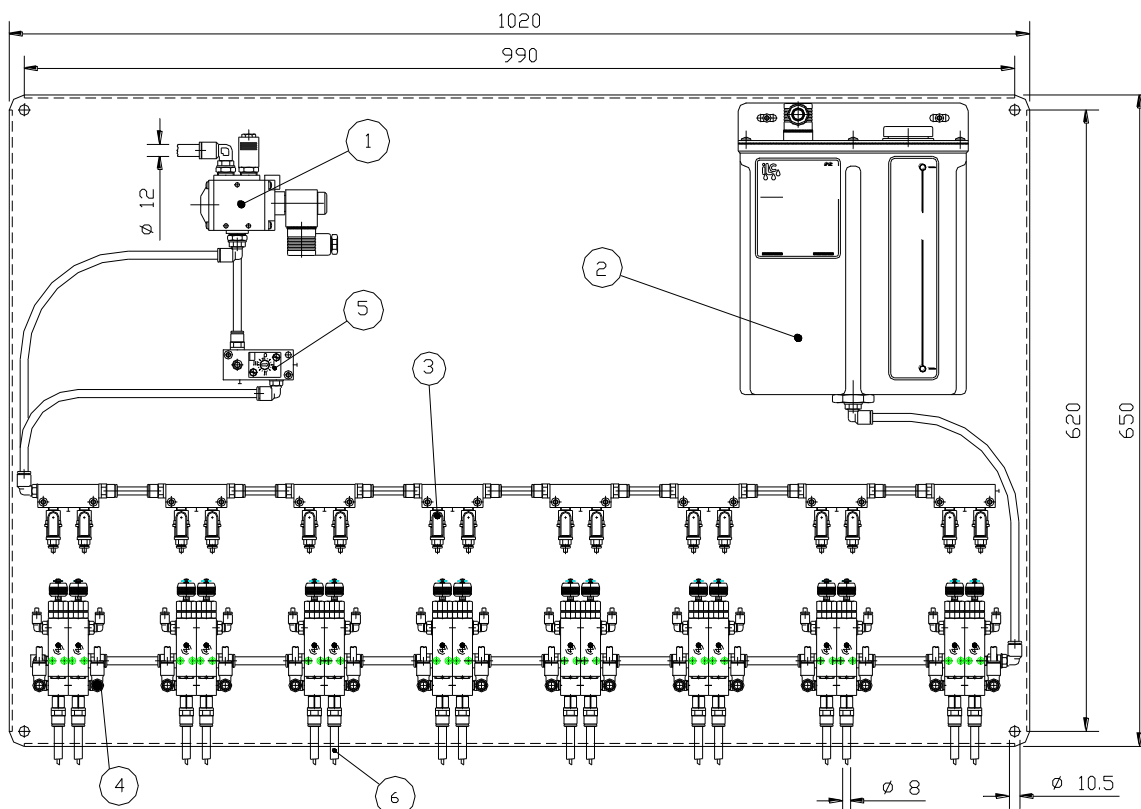

Modification of indicated specifications and design reserved

Pos.	DESCRIPTION
1.	Solenoid valve
2.	Plastic reservoir, 6 L
3.	Air manifold with valve ON / OFF
4.	Air regulator
5.	Frequency generator
6.	Coaxial hoses – 5m length, 8mm tube

MICRO LUBRICATION OIL + EMULSION

This system is used, for example, for cutting with a circular saw, for machines with high production and for machines where it is necessary to use micro lubrication together with the traditional use of emulsion.

A special output nozzle (see nozzle saddles for circular saws, page 41 of this catalogue) is applied an oil to the front surfaces of the teeth. At the same time, the emulsion is applied to the side surfaces of the cutting disc. The result of this combination is a high cutting quality and a long tool life.

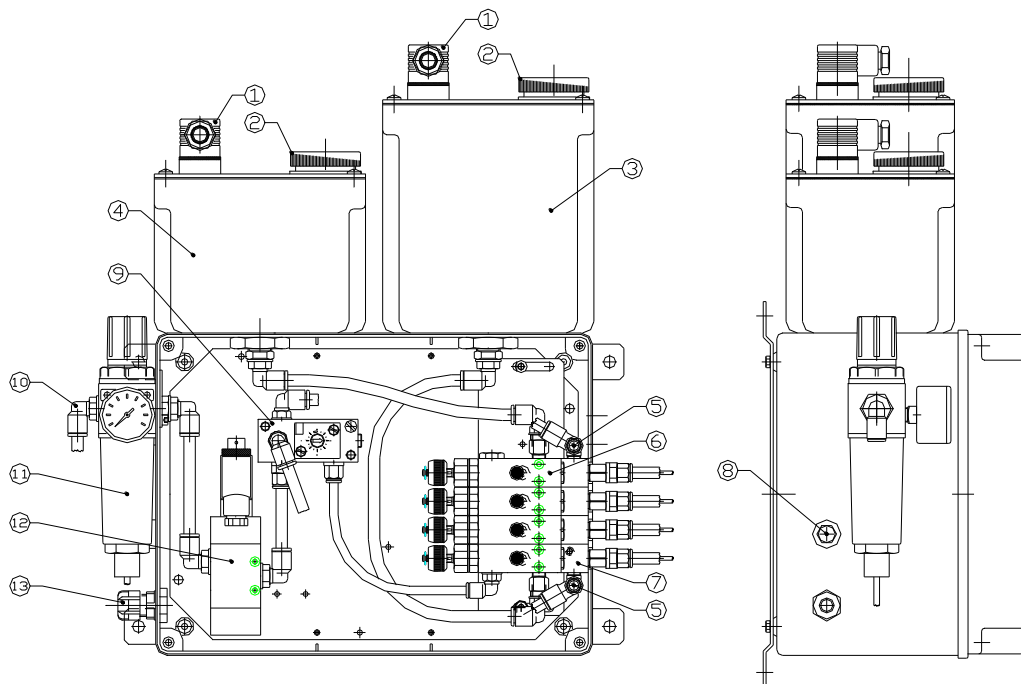

Pos.	DESCRIPTION
1.	MIN. signalling level
2.	Filling plug with filter
3.	Plastic reservoir 2.2 L emulsion
4.	Plastic reservoir, 1.2 L oil
5.	Air regulator
6.	3 or 4 pumping units
7.	3 or 4 mounting bases for pump. units
8.	Aeration filter
9.	Frequency generator
10.	Air supply fitting, tube 8 mm
11.	Air regulator with manometer
12.	Solenoid valve
13.	Cable inlet
Coaxial hoses – 5m length (6mm tube and 2,5mm tube)	

Modification of indicated specifications and design reserved

DIMENSION DRAWING

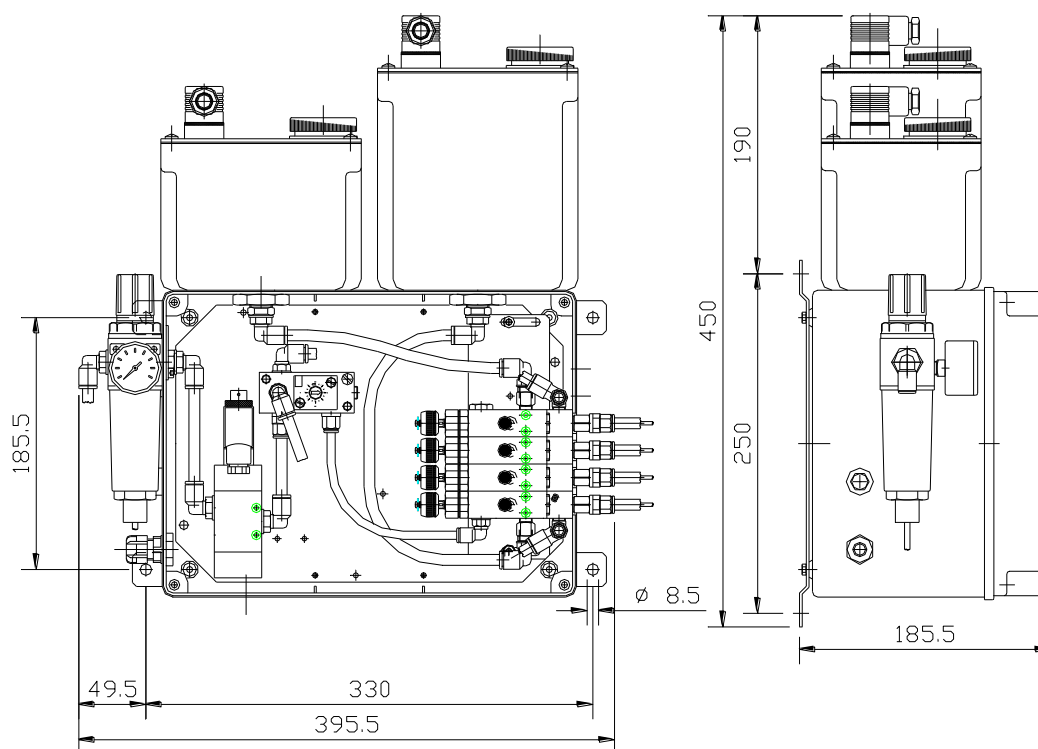

TECHNICAL SPECIFICATION

Dose	from 0 to 39mm ³ /stroke	Lubricant	oil max. 800 cSt 40°C
Number of pumps	from 3 to 7	Cabinet	metal
Strokes	from 66 to 1/min.	Electromagnetic valve	24 V DC, 24 V AC, 115 V AC, 230 V AC
Reservoir	plastic 1.2 L oil plastic 2.2 L emulsion	MIN. level signalling	1 A, 250 V AC, 200DC, 50 W

ORDERING CODES

CODE	TYPE	NUMBER OF PUMPING UNITS
1700603	MIX 1 (OIL) + 2 (EMULSION)	3
1700604	MIX 2 (OIL) + 2 (EMULSION)	4

VOLTAGE OF SOLENOID VALVE COIL MUST BE INCLUDED IN ORDER FOR MICRO LUBRICATION CODE. CODE: 1146601 COIL 24V DC – CODE: 1146602 COIL 115V AC – CODE: 1146603 COIL 230V AC – CODE: 1146604 COIL 2 4V AC.

Modification of indicated specifications and design reserved

TERMINAL TUBE WITH NOZZLE – DIMENSION DRAWING

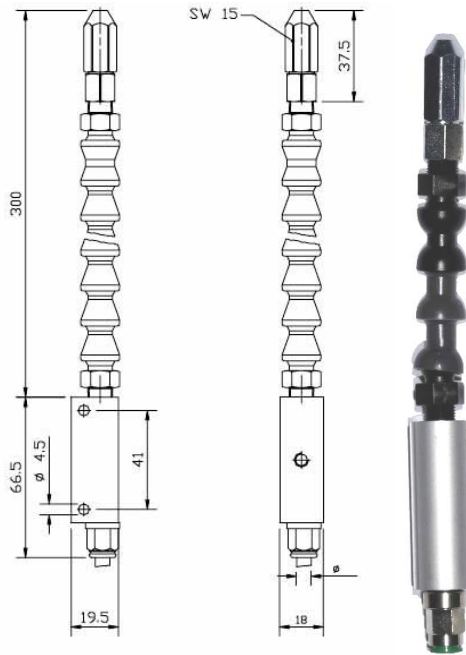

Loc-line support with fixed base - 1701000 (Ø6)
Loc-line support with fixed base - 1701010 (Ø8)

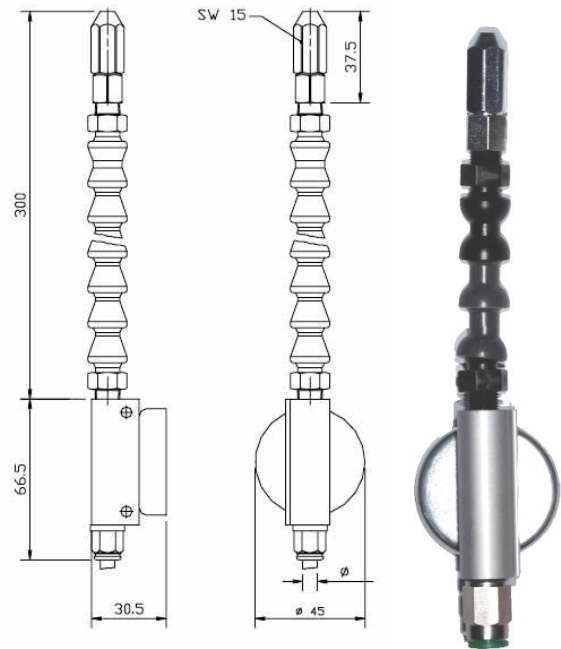

Loc-line support with magnetic base - 1701002 (Ø6)
Loc-line support with magnetic base - 1701012 (Ø8)

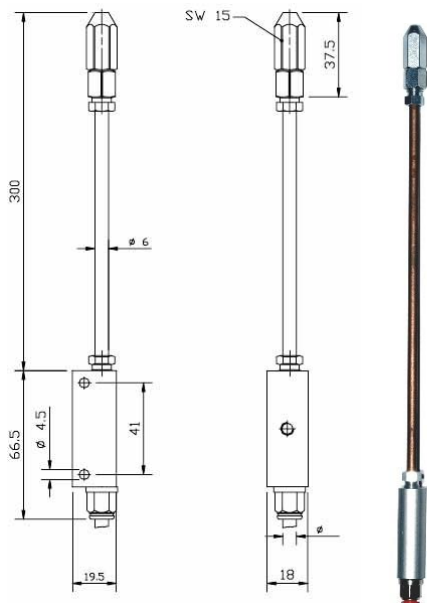

Steel tube with fixed base - 1701001 (Ø6)
Steel tube with fixed base - 1701011 (Ø8)

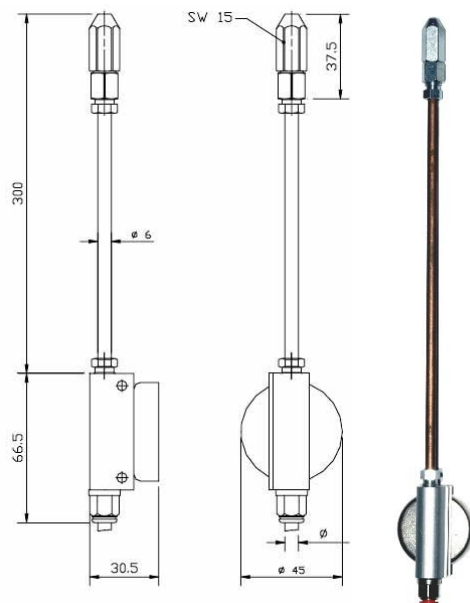

Steel tube with magnetic base - 1701003 (Ø6)
Steel tube with magnetic base - 1701013 (Ø8)

Codes include nozzle, steel or Loc-line support and magnetic or fixed base.

Modification of indicated specifications and design reserved

NOZZLES WITH G 1/8" THREADS – DIMENSION DRAWING

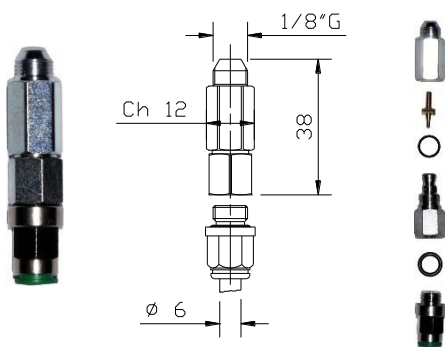

Code: 790870093181

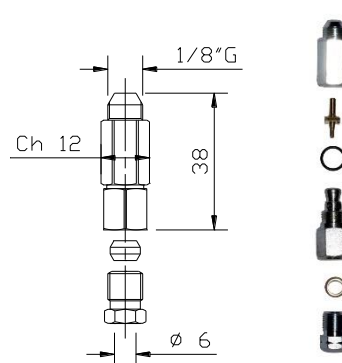

Code: 790870093178

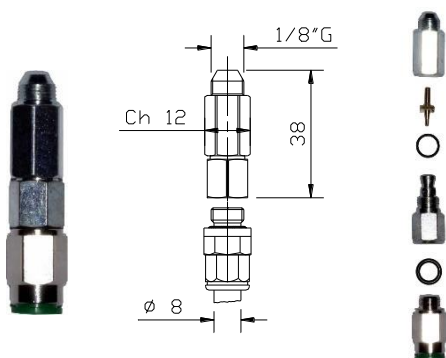

Code: 790870093246

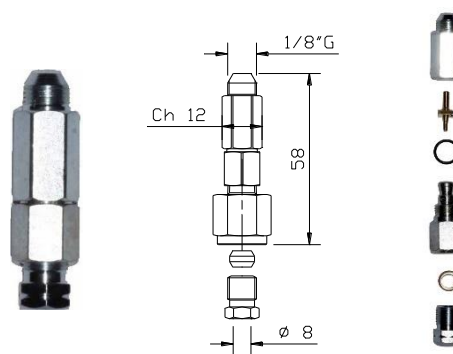

Code: 790870093248

LOC-LINE WITH FIXED BASE – CODE: 1701038

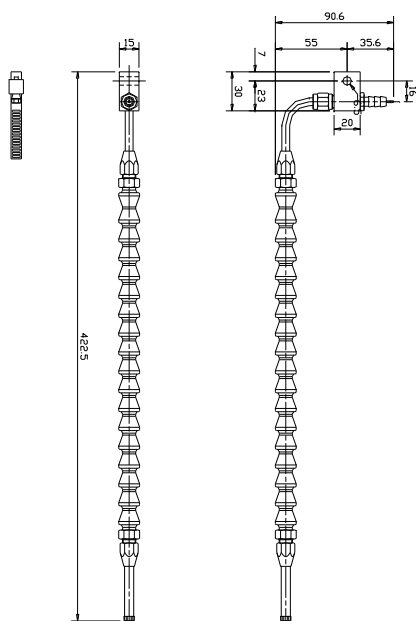

Modification of indicated specifications and design reserved

NOZZLE SADDLE FOR HORIZONTAL BEND SAW

Saw blade height: from 6 up to 34 mm

Lubricant: oil

CODE	NUMBER OF INLETS	NUMBER OF OUTLETS
1701110	1	3

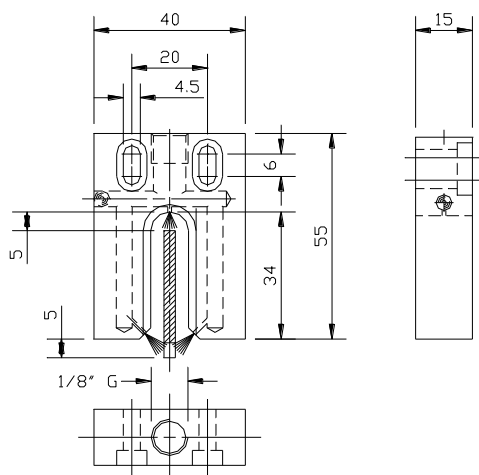

Saw blade height: from 41 up to 80 mm

Lubricant: oil

CODE	NUMBER OF INLETS	NUMBER OF OUTLETS	Height mm	A mm	B mm	C mm
1701111	2	5	41	41	39	60
1701112	2	5	54	54	52	73
1701113	2	5	67	67	65	86
1701114	2	5	80	80	78	99

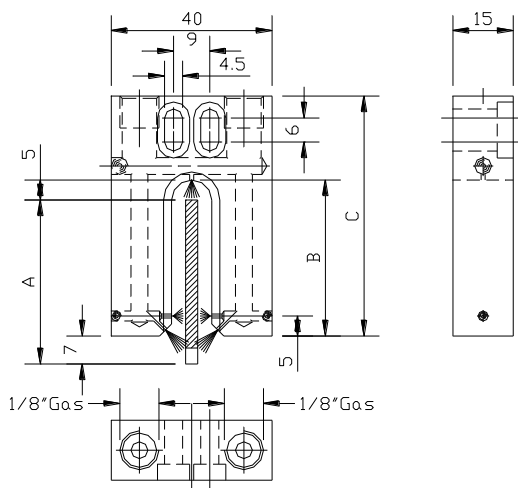

Modification of indicated specifications and design reserved

NOZZLE SADDLE FOR VERTICAL BAND SAW

Saw blade height: from 6 up to 34 mm

Lubricant: oil

CODE	NUMBER OF INLETS	NUMBER OF OUTLETS
1701120	1	3

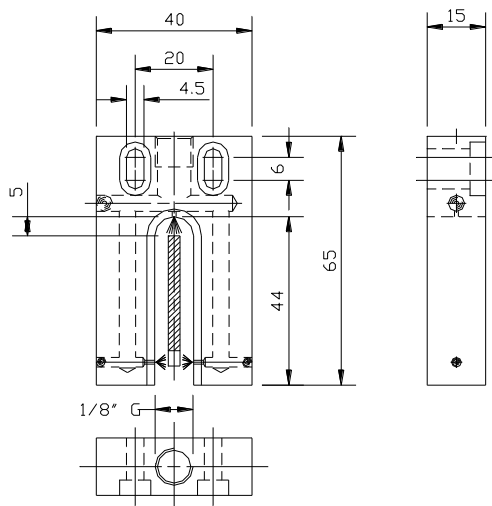

Saw blade height: from 41 up to 80 mm

Lubricant: oil

CODE	NUMBER OF INLETS	NUMBER OF OUTLETS	Height mm	A mm	B mm	C mm
1701121	2	5	41	41	49	70
1701122	2	5	54	54	62	83
1701123	2	5	67	67	75	96
1701124	2	5	80	80	88	109

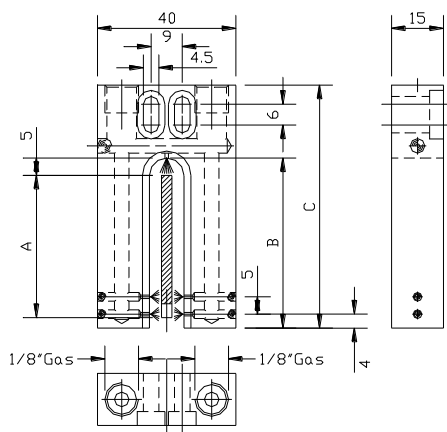

Modification of indicated specifications and design reserved

NOZZLE SADDLE FOR HORIZONTAL BEND SAW

Saw blade height: from 6 up to 34 mm

Lubricant: emulsion

CODE	NUMBER OF INLETS	NUMBER OF OUTLETS
1701130	2	6

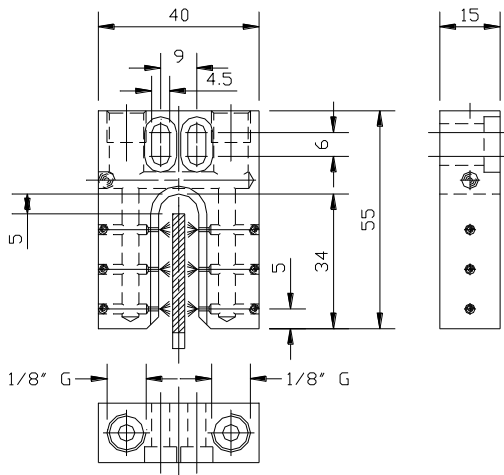

Saw blade height: from 41 up to 80 mm

Lubricant: emulsion

CODE	NUMBER OF INLETS	NUMBER OF OUTLETS	Height mm	A mm	B mm	C mm
1701131	2	6	41	41	39	60
1701132	2	8	54	54	52	73
1701133	2	10	67	67	65	86
1701134	2	12	80	80	78	99

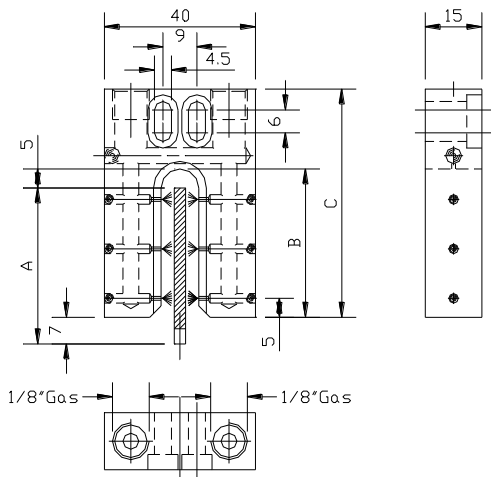

Modification of indicated specifications and design reserved

NOZZLE SADDLE FOR VERTICAL BAND SAW

Saw blade height: from 6 up to 34 mm

Lubricant: emulsion

CODE	NUMBER OF INLETS	NUMBER OF OUTLETS
1701140	2	6

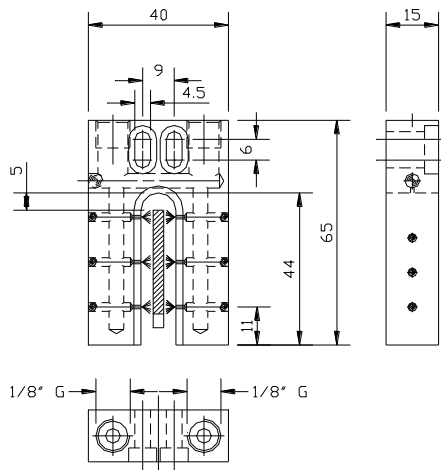

Saw blade height: from 41 up to 80 mm

Lubricant: emulsion

CODE	NUMBER OF INLETS	NUMBER OF OUTLETS	Height mm	A mm	B mm	C mm
1701141	2	6	41	41	49	70
1701142	2	8	54	54	62	83
1701143	2	10	67	67	75	96
1701144	2	12	80	80	88	109

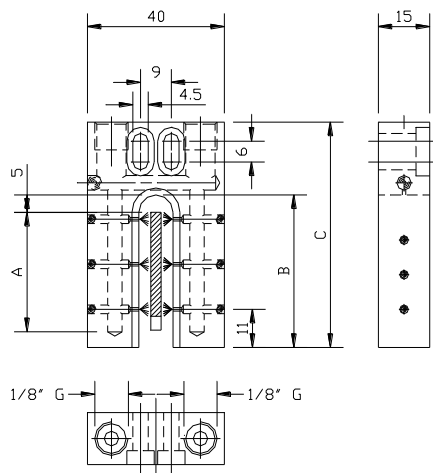

CODE	NUMBER OF INLETS	NUMBER OF OUTLETS
1701062	2	5

Modification of indicated specifications and design reserved

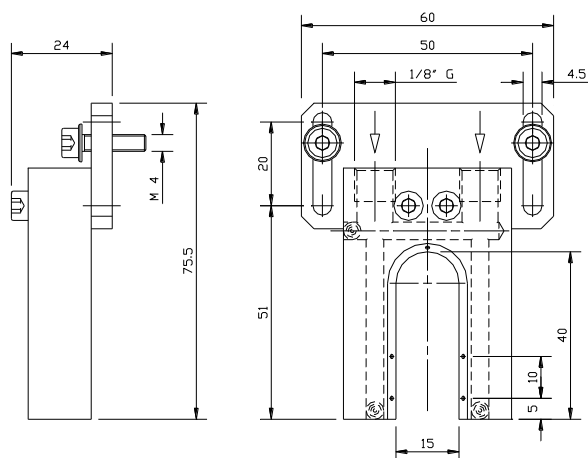

CODE	NUMBER OF INLETS	NUMBER OF OUTLETS	CODE	NUMBER OF INLETS	NUMBER OF OUTLETS
1701032	1	3	1701035	1	3

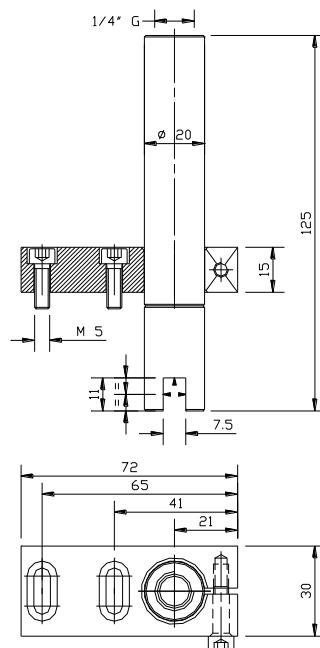
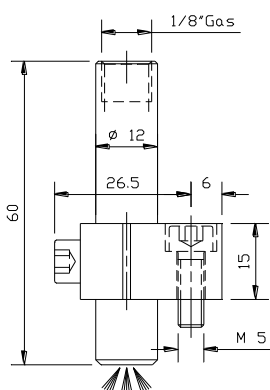
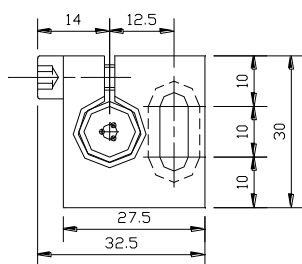

Modification of indicated specifications and design reserved

NOZZLE SADDLE FOR CIRCULAR SAW

Lubricant: oil + emulsion

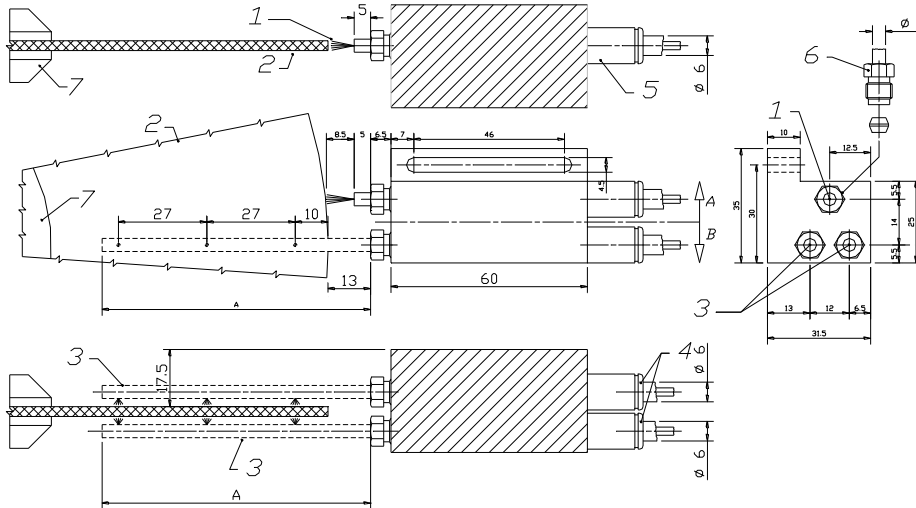

POS.	DESCRIPTION
1.	Outlet nozzle
2.	Saw disc
3.	Emulsion nozzles
4.	Push-in fitting, tube 6mm – for emulsion
5.	Push-in fitting, tube 6 mm – for oil
6.	Cutting ring and nut, tube dia. 4 mm



CODE	NUMBER OF OUTLETS FOR EMULSION	DISC DIAMETER ()	A mm
790870103455	2 + 2	175 – 200	55
790870103482	3 + 3	225 – 250 – 275	82
798701034109	4 + 4	300 – 315 – 350 – 370 - 400	109

SEMI-CONNECTING PART FOR COAXIAL HOSE diam. 8x6 mm and 3x1,5mm

Code: 790870093230

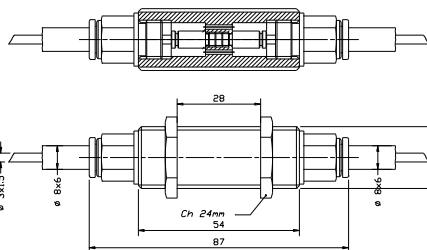

Modification of indicated specifications and design reserved

RECOMMENDED PROCEDURE WHEN USING THE LUBETOOLS SYSTEM

LUBETOOLS is a new generation lubrication system that is very environmentally friendly. The use of plant-based lubricants contributes to the fact that your tools last longer and that the machining result is a dry workpiece with a better surface finish. Another positive aspect is that no hazardous fumes are released during machining and that chips or sawdust remain dry after machining, making it easier for you to keep your machine clean.

An adjustable pump transports the lubricant through a capillary hose to the nozzle. The air pressure allows the lubricant to be spread evenly across the tool. Lubricant molecules form a thin, uniform coating on tools that reduces heat generated by friction.

VERY IMPORTANT:

THE LUBRICANT MUST BE ON THE TOOL BEFORE THE TOOL COMES INTO CONTACT WITH THE SURFACE.

The number of the used nozzles depends on the material and the machining method.

BAND AND CIRCULAR SAW CUTTING

STRIP SAW

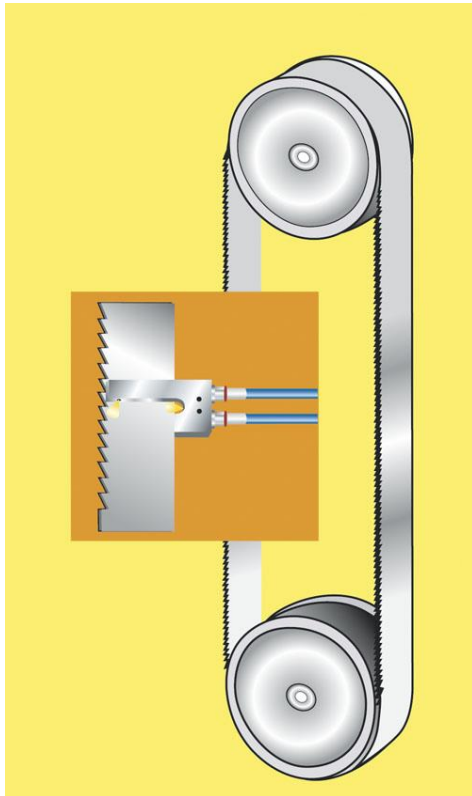

Saw blade height from 6 up to 34 mm: 1 inlet - 3 outlets
Saw blade height from 6 up to 34 mm: 2 inlets - 3 outlets

CIRCULAR SAW



Saw diameter from 175 up to 225mm: 1 inlet up to 3 outlets
Saw diameter from 250 up to 400mm: 2 inlets – 5 outlets

Modification of indicated specifications and design reserved

DRILLING AND CUTTING INNER THREADS

INNER THREAD CUTTING

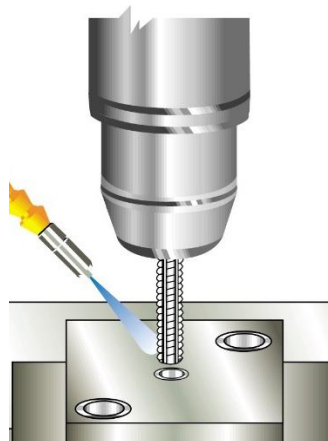

Tool from 3 up to 10 mm: 1 nozzle
 Tool from 11 up to 20 mm: 2 nozzles
 Tool from 21 up to 40 mm: 3 nozzles
 Tool from 41 up to 60 mm: 4 nozzles

DRILLING



Tool from 1 up to 12 mm: 1 nozzle
 Tool from 13 up to 24 mm: 2 nozzles
 Tool from 25 up to 48 mm: 3 nozzles
 Tool from 49 up to 60 mm: 4 nozzles

MILLING

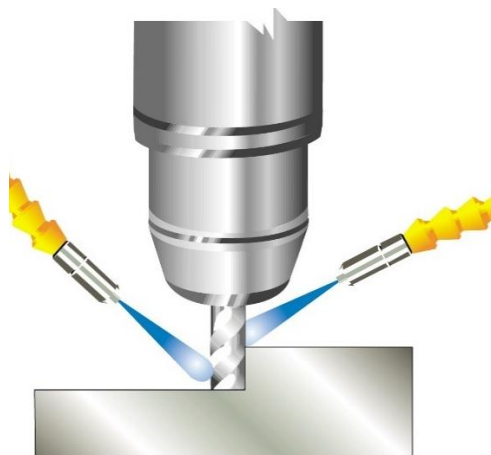

Tool from 1 up to 12 mm: 1 nozzle
 Tool from 13 up to 40 mm: 2 nozzles

Tool from 41 up to 100 mm: 3 nozzles
 Tool from 101 up to 240 mm: 4 nozzles

Modification of indicated specifications and design reserved

CHAIN MICROLUBRICATION

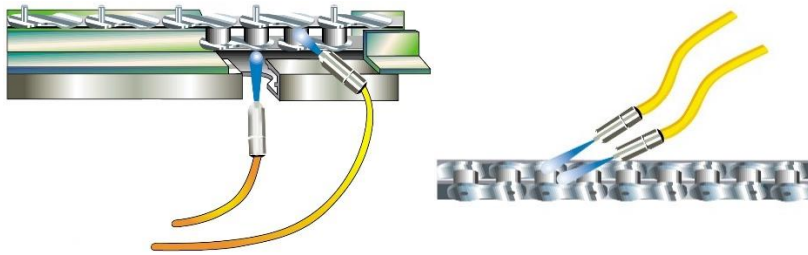

MICRO-LUBRICATION DURING SHEET METAL FORMING

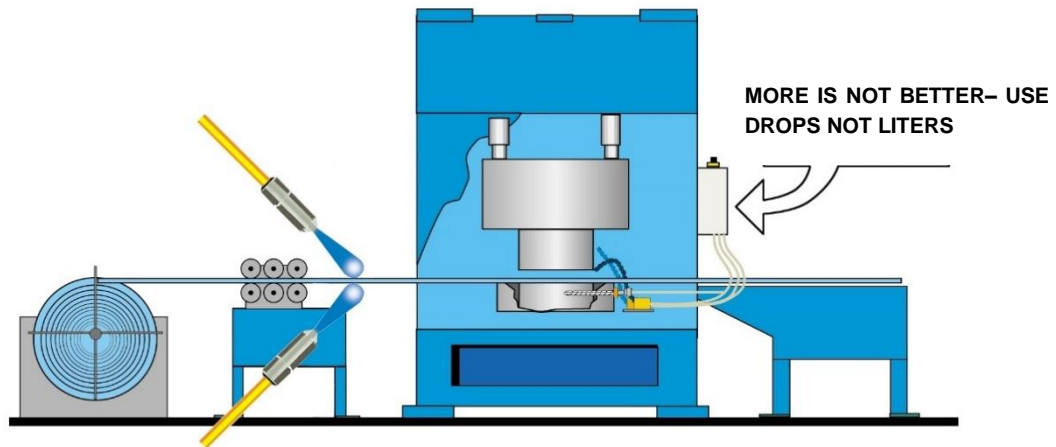

NOZZLE ADJUSTING

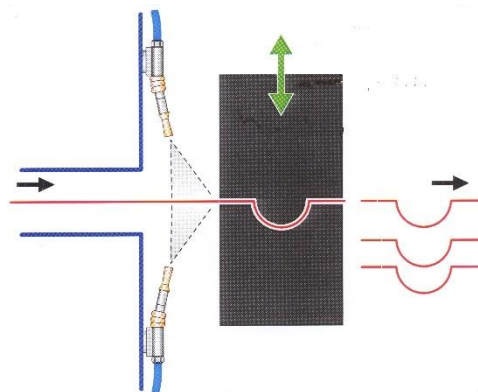

- nozzle distance from spraying surface: 100 up to 150 mm
- distance among nozzles: 100 mm
- angle 45° according to figure (given values are indicative)

Modification of indicated specifications and design reserved

LUBETOOLS MICROLUBRICATION – ASSEMBLY AND CONNECTION

1. LUBETOOLS system can be fixed in the desired position using the anchor holes made for each type.
2. Adjust the coaxial hoses to the exact length. If this length is less than 5 m, cut off the unnecessary part. It must be ensured that the inner hose is 0.5 m longer than the outer hose.
3. Remove the hex head from the Loc-line or the steel pipe.
4. Remove the nozzle.
5. Insert the inner hose in the direction from the mounting base to the end of the Loc-line or steel pipe.
6. Connect the outer hose to the mounting base.
7. Cut the inner hose off.
8. Connect the nozzle.
9. Connect the hexagonal head.

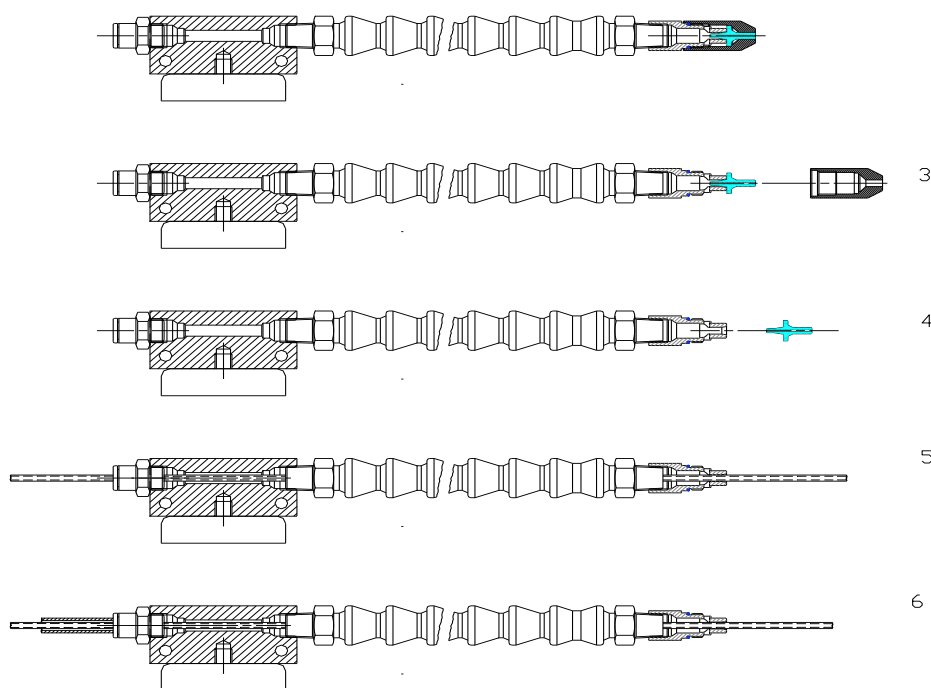

Modification of indicated specifications and design reserved

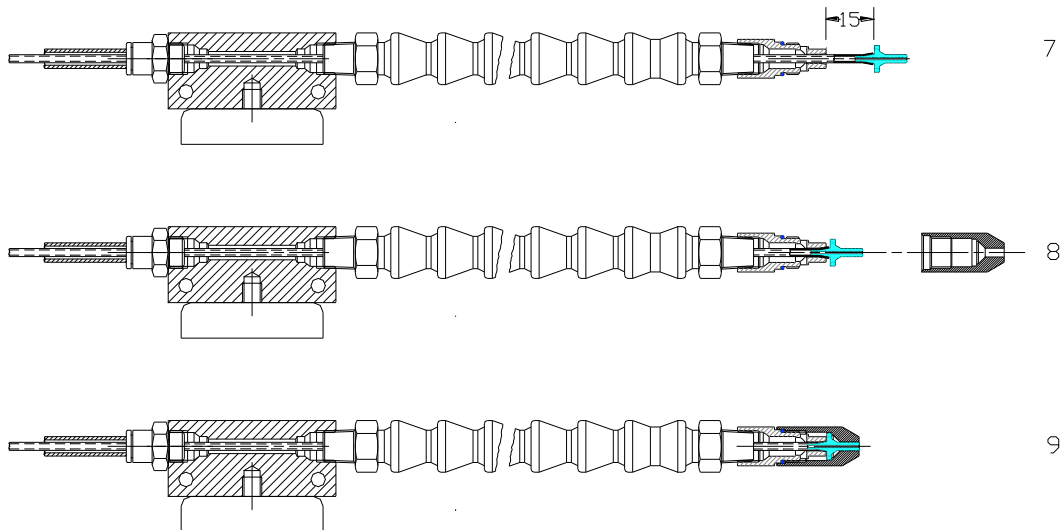

10. The nozzle holder must be fixed close to the application point for an optimal effect at a correct distance to the lubricated area. The magnetic bases are supplied so that different places can be covered.
11. Compressed air supply is connected via 8 mm inlet (push-in) fitting. The air must be completely oil-free, dry and clean – which is achieved by using a standard 5 μm mechanical particle filter. The working air pressure is from 5 bar (75 psi) to 10 bar (150 psi). These conditions are the same even if the air is supplied by two separate hoses.
12. The solenoid valve is supplied with PG-9 connector for an electrical connection. When the valve is energized, the air can flow into the frequency generator and nozzle. The solenoid valve must be energized before the tool starts machining and must remain energized until the tool stops machining. For all LUBETOOLS systems that are not equipped with solenoid valves, this must be handled externally.
13. The tank is equipped with a minimum level signalling (the switch) with PG-9 connector. The contact is open when the tank is full and closes when the minimum level in the tank is reached. This contact can also be used to the signal of a system failure.
14. The shut-off valve should be set to supply air at a pressure of 0.5 bar (8 psi) to 3 bar (45 psi). We recommend using 1.5 bar (22 psi) pressure.

FILLING (FIRST FILLING) LUBETOOLS SYSTEM UP

1. Before putting the system into operation for the first time, the system must be filled in. If the lubricant level doesn't drop under MIN. level, no further filling of the system is not needed.
2. Filling the system is done as follows:
 - Fill the reservoir with lubricant and leave the cap removed to allow free ventilation during phase filling.
 - Loosen the drain plug slightly with 5 mm Allen key and drain the grease until it flows completely free of air bubbles.
 - Increase the frequency of the frequency generator to the maximum.
 - Finish the valve stroke adjustment of the pump to a maximum lubricant dose.
 - Connect the voltage to the solenoid valve to connect a compressed air and observe the movement of air bubbles in the capillary until the hose is completely free of bubbles along its length.
 - When the filling process has been completed, set the frequency generator and a piston stroke to operating values.
 - The system is got ready under operation.

MICRO-LUBRICATION LUBETOOLS – SPARE PARTS

RESERVOIRS

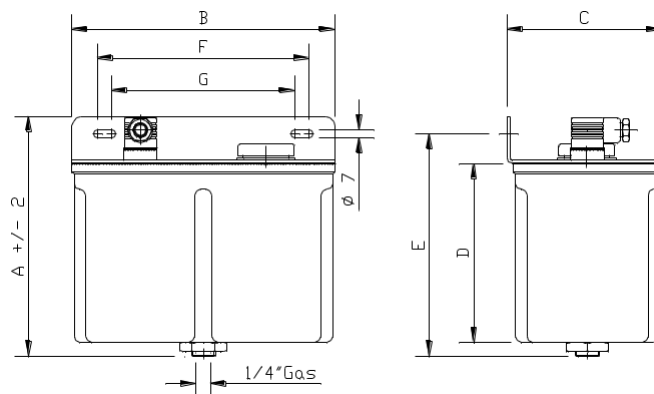

CODE	VOLUME (L)	LOW LEVEL SWITCH	A mm	B mm	C mm	D mm	E mm	F mm	G mm
790872079263	1.2 / Polypropylene	-	161	148	123	108	146	132	125
790872079264	2.2 / Polypropylene	-	213	148	123	160	198	132	125
790872079265	3.6 / Polypropylene	-	208	230	135	155	193	185	160
790872079269	6.0 Nylon	-	303	230	135	250	288	185	160
790872079260	1.2/ Polypropylene	Yes	161	148	123	108	146	132	125
790872079261	2.2 / Polypropylene	Yes	213	148	123	160	198	132	125
790872079262	3.6 /Polypropylene	Yes	208	230	135	155	193	185	160
790872079268	6.0 Nylon	Yes	303	230	135	250	288	185	160

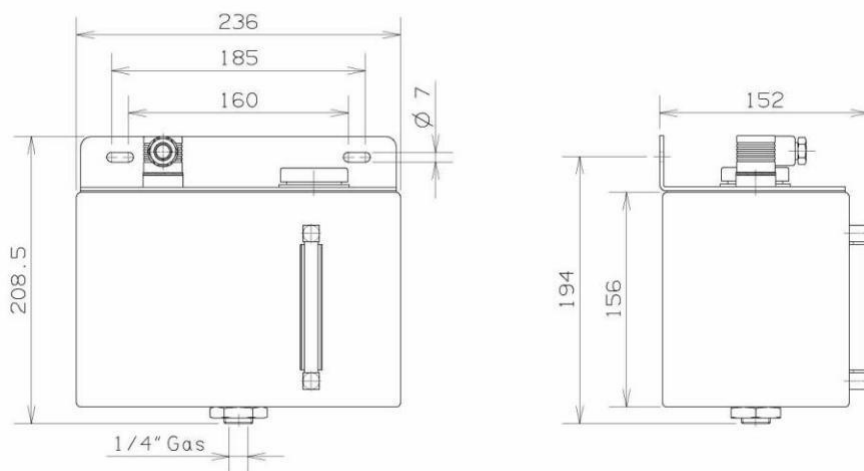

CODE	CAPACITY (L)	LOW LEVEL SWITCH
790872079399	3,6/Metallic	Yes
798720793997	3,6/Metallic	-

Modification of indicated specifications and design reserved

CODE	VOLUME (L)	LOW LEVEL SWITCH	A mm	B mm	C mm	D mm	E mm	F mm
790872079415	8 /Metallic	Yes	305	330	163	252	205	305
790872079324	12/Metallic	Yes	305	355	196	252	205	330
790872079420	50/Metallic	Yes	452	560	266	400	300	530
798720794157	8/Metallic	-	282	330	163	252	205	305
798720793247	12/Metallic	-	282	355	196	252	205	330
798720794207	50/Metallic	-	429	560	266	400	300	530

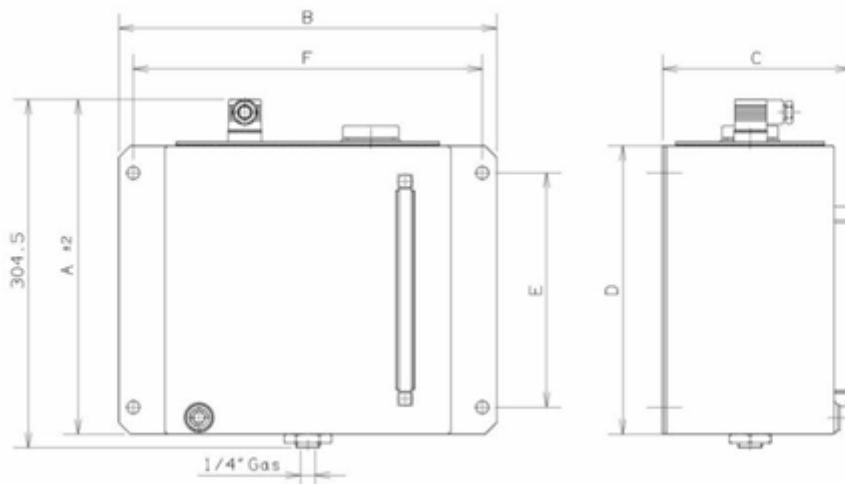

LOW LEVEL SWITCHES

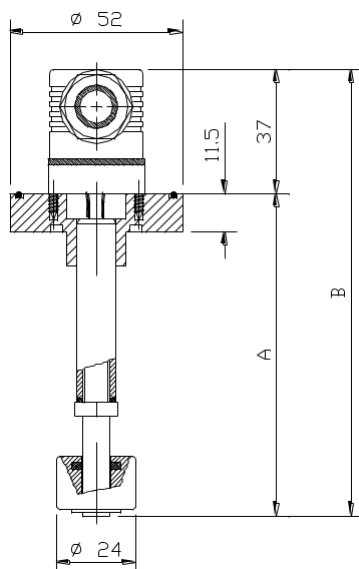

CODE	RESERVOIR (L)	A (mm)	B (mm)
790870094040	1.20	97	133.5
790870094029	2.20	144	181
790870094029	3.60	144	181
790870094037	6.00	240	277

Modification of indicated specifications and design reserved

ADAPTORS FOR MINI LUBETOOLS WITH 1 OR 2 PUMPS

1 PUMP – CODE: 790851106208

2 PUMPS - CODE: 790851106215

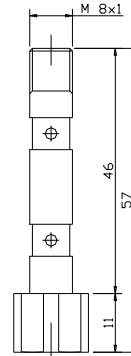
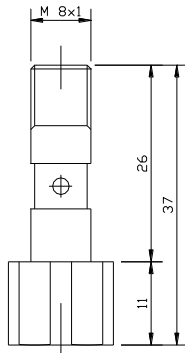

**BRACKET TO INSTALL THE BASE PUMPS (FROM 1 TO 6 PUMPS)
CODE: 790885120401**

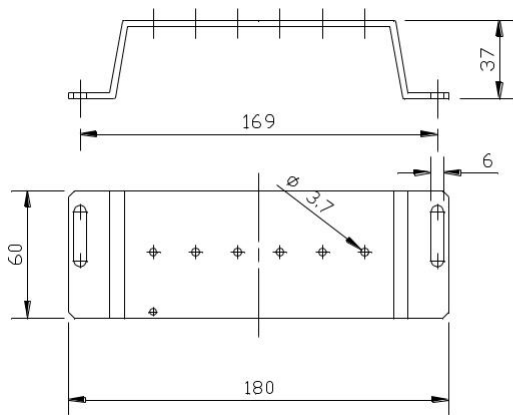

TIE-RODS TO JOIN THE PUMP BASES (FROM 1 TO 6)

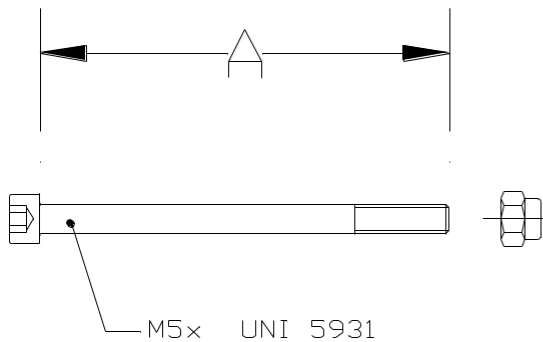

Modification of indicated specifications and design reserved

CODE	OUTLETS	A (mm)
790870093167 (x2)	2	35
790870093168 (x2)	3	55
790870093169 (x2)	4	75
790870093170 (x2)	5	95
790870093171 (x2)	6	115

MICRO-LUBRICATION PUMP BASE, CODE: 790870093165

THIS CODE INCLUDES ALL ITEMS SHOWN ON THE DRAWING BELOW

ONLY COMPLETE MOUNTING BASES ARE SUPPLIED, CODE: 790870093165.

PLEASE SPECIFY OUTER DIAMETER 6 mm or 8 mm of COAXIAL HOSE IN ORDER



POS.	CODE	DESCRIPTION
1.	790892127109	"O"- RING 11x1
2.	790851096055	PLUG
3.	790873087010	PLUG
4.	790892127108	"O"-RING 2018
5.	1032310	ELBOW ADAPTOR
6.	790892127106	"O"-RING 2010
7.	790892127109	"O"- RING 2037
8.	UNI5931-M5X25	SCREW M5x25 UNI 5931
9.	790883082081	SINGLE MOUNTING BASE
10.	790870093219	DELIVERY FITTING + 5 M COAXIAL TUBE – 6 mm
11.	790870093228	DELIVERY FITTING + 5 M COAXIAL TUBE – 8 mm

**MICRO PNEUMATIC PUMP TO BE INSTALLED ON MOUNTING BASE
CODE: 790870093463**

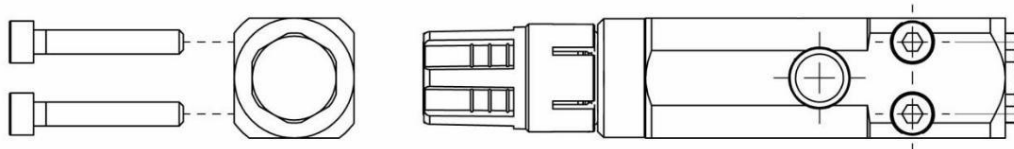

Modification of indicated specifications and design reserved

FITTINGS FOR PUMP BASE

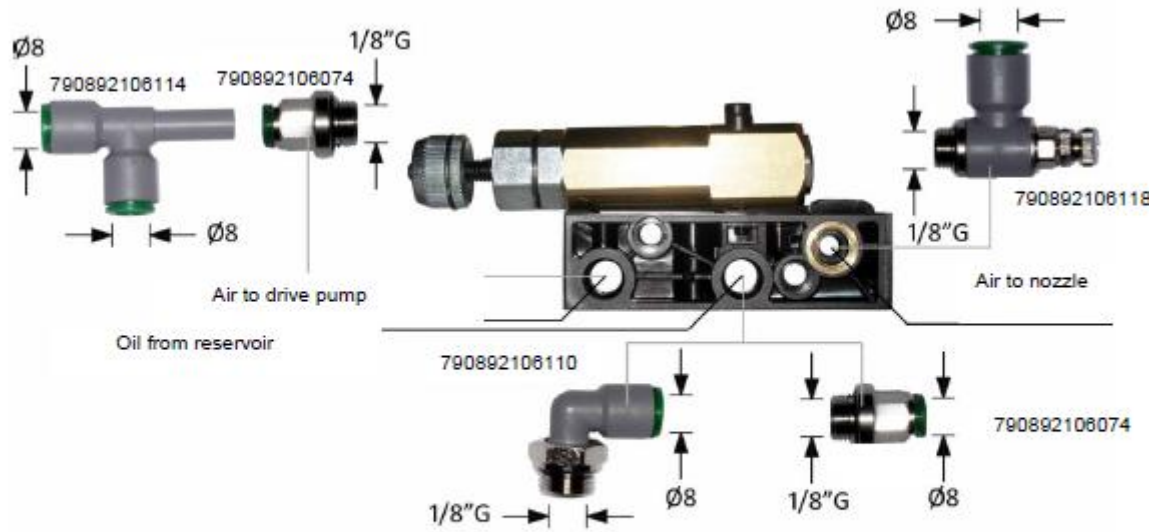

PLUG G1/8"
CODE 790892087058

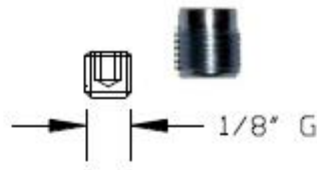

NOZZLE COMPLETE OF FITTING FOR TUBE 6 MM

CODE 790870093172
NUT AND OLIVE FITTING

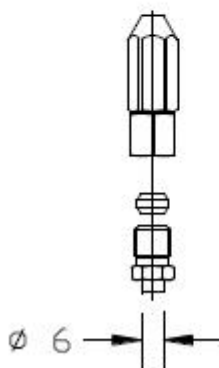

CODE 790870093180
PUSH-IN FITTING

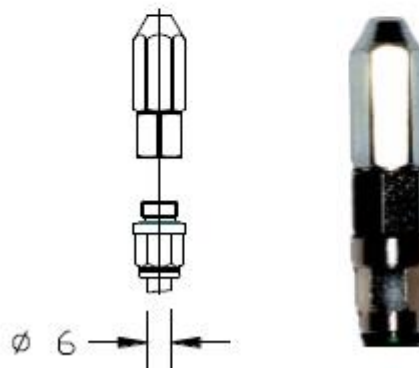

Modification of indicated specifications and design reserved

COMPLETE FREQUENCY GENERATOR WITH MOUNTING BASE, CODE: 790872079243

FREQUENCY GENERATOR
CODE: 1146500



FREQUENCY GENERATOR
WITH MOUNTING BASE
CODE: 790853082046

COMPLETE FREQUENCY GENERATOR WITH MOUNTING BASE, CODE: 790872079321

THIS GENERATOR IS INSTALLED IN THE LUBETOOLS MINI DESIGN FOR 1 OR 2 PUMPS



FREQUENCY GENERATOR
CODE: 1146500



FREQUENCY GENERATOR
WITH BASE
CODE: 790853082087

FLOW CONNECTING BOLT, CODE: 790851106202
+ GASKET (2X) CODE: 790892127109

CONNECTING FITTINGS

CODE	TYPE	FIG.
790892106113 790892106074 790892106123	Air straight push-in fitting tube 6 mm G1/8 Air straight push-in fitting tube 8 mm G1/8 Straight push-in fitting tube 8 mm G1/4 (from reservoir)	
790892106195 790892106110 790892106248	Air elbow push-in fitting tube 6 mm G1/8 Air elbow push-in fitting tube 8 mm G1/8 Elbow push-in fitting tube 8 mm G1/4 (from reservoir)	

Modification of indicated specifications and design reserved

TERMINAL TUBES WITH FLAT NOZZLE

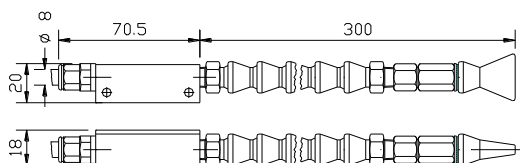

CODE:1701020

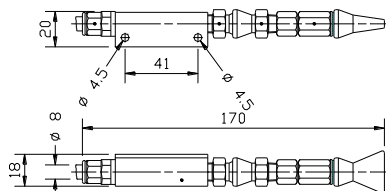

CODE:1701024

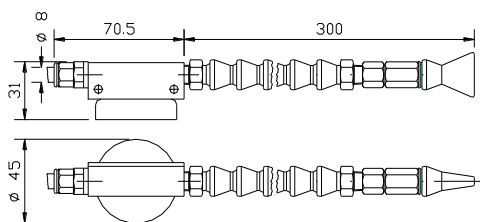

CODE:1701021

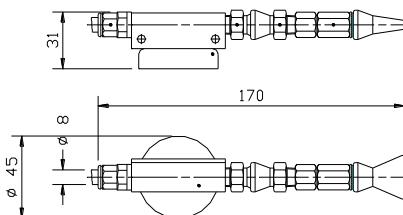

CODE:1701025



TERMINAL TUBES WITH CONICAL NOZZLE

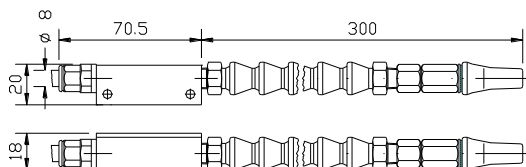

CODE:1701022

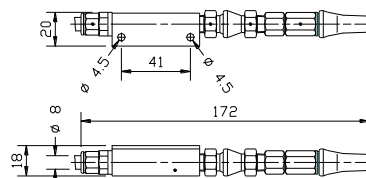

CODE:1701029

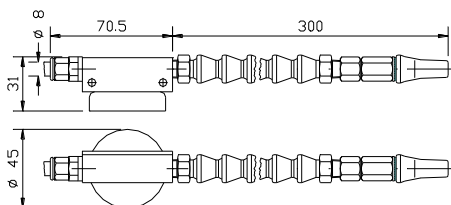

CODE:1701023

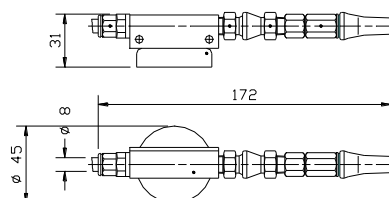

CODE:1701028



Modification of indicated specifications and design reserved